

USER MANUAL

WEIGHT INDICATOR

MICROCONTROLLER



E-BATCH: SOFTWARE FOR MULTICOMPONENT DOSAGE SYSTEMS

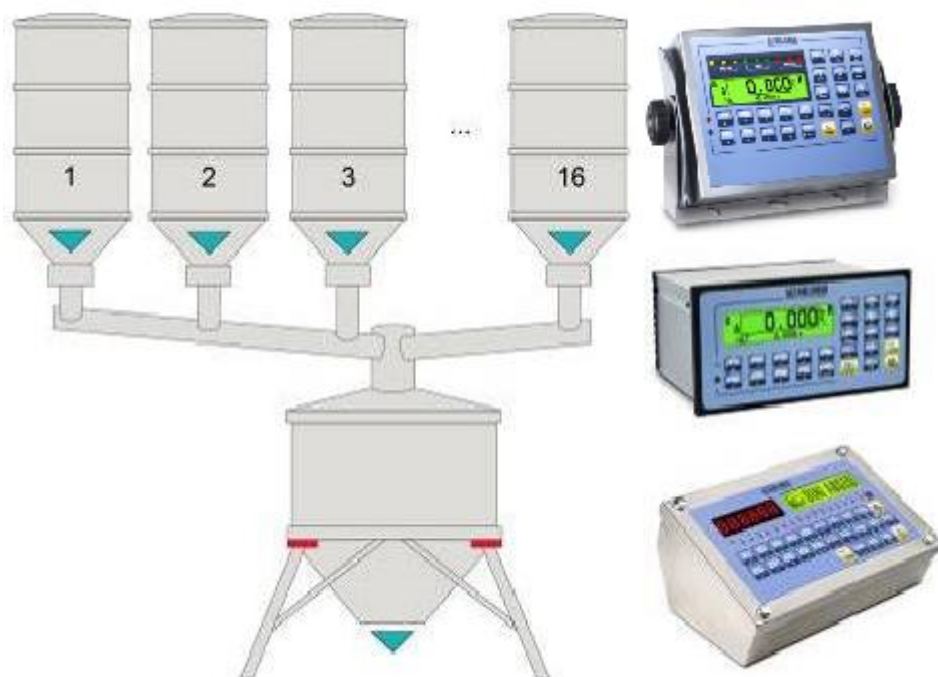

JIM SMITH COMPANY
17, MAIN STREET
NEW YORK, NY U.S.A

TEST
TARGET 110kg
CYCLE REPORT 01
9/11/09 - 15:22

01 AUTOM. DOSAGE
GRAVEL
SCALE NUMBER 1
DOSE 50kg
DOSED WEIGHT 50kg

02 MANUAL DOSAGE
SAND
SCALE NUMBER 1
DOSE 50kg
DOSED WEIGHT 50kg

CYCLE REPORT
9/11/09 - 15:30
TARGET 110kg
DOSED 110kg
OUT OF TOL. 0kg

3590EXTBATCHBCIO, CPWEBATCH, CPWETF series indicator



INDEX

1. INTRODUCTION	4
2. MAIN TECHNICAL SPECIFICATIONS	5
2.1 ACCESSORIES AVAILABLE	6
2.1 ACCESSORIES AVAILABLE	6
2.2 SYMBOLS.....	6
3. INSTALLATION	7
3.1 CPWE DRILLING TEMPLATE, CASE AND DIMENSIONS	7
3.2 3590E CASE AND DIMENSIONS	8
3.3 CPWETF CASE AND DIMENSIONS	9
3.4 POWER SUPPLY & START UP	10
3.5 CONNECTION TO THE BATTERY POWERED PRINTER.....	10
4. FUNCTION PANEL KEYS	11
4.1 FUNCTION OF THE KEYS	13
4.1.1 "2ndF" KEY: SECOND FUNCTION OF THE KEYS.....	14
4.1.2 ENTERING ALPHANUMERIC TEXT	14
4.1.3 DISABLING THE KEYBOARD.....	15
4.1.4 HELP MENU.....	15
4.1.5 INDICATOR CONNECTED TO REMOTE KEYBOARD	15
4.2 DISPLAY FUNCTIONS	16
4.2.1 WEIGHT ZOOM.....	17
4.2.2 STATUS INDICATORS – 3590 Model.....	18
4.2.3 BATTERY LEVEL INDICATION	19
4.2.4 SELECTABLE INFO	20
4.2.5 SYSTEM STATUS INFO	23
4.2.6 MESSAGES OF THE INSTRUMENT	24
5. SCALE SELECTION	26
6. SCALE ZERO FUNCTION	26
7. TARE FUNCTIONS	27
7.1 SEMIAUTOMATIC TARE	27
7.2 PRESET TARE	27
7.3 CALCULATED MANUAL TARE	27
7.4 TARE CANCELLATION	27
7.5 LOCKED/UNLOCKED TARE	27
7.6 LIMITATION OF THE TARE FUNCTIONS	28
7.7 AUTOMATIC ACQUISITION OF THE TARE AT CYCLE BEGINNING	28
7.8 RESTORING TARE AND ZERO AT THE START-UP.....	28
8. MULTIRANGE FUNCTION	28
9. DISPLAY OF METRIC DATA (inFO)	28
10. ENTERING ALPHANUMERIC TEXT	29
11.1 ACTIVITY DATABASE	30
11.1.1 ENTRY	30
11.1.2 MODIFICATION OF AN ACTIVITY IN THE DATABASE	33
11.1.3 CANCELLATION OF AN ACTIVITY IN THE DATABASE.....	33
11.1.4 PRINT OF ACTIVITIES IN THE DATABASE.....	33
11.1.5 ALPHABETICAL RESEARCH	33
11.1.6 HELP	33
11.2 FORMULA DATABASE.....	34
11.2.1 ENTERING A FORMULA IN THE DATABASE.....	34
11.2.2 SELECTION OF A FORMULA IN THE DATABASE	35
11.2.3 DESELECTION OF A FORMULA IN THE DATABASE	35
11.2.4 MODIFICATION OF A FORMULA IN THE DATABASE	35
11.2.5 CANCELLATION OF A FORMULA IN THE DATABASE	36
11.2.6 PRINT OF FORMULAS IN THE DATABASE	36
11.2.7 ALPHABETICAL RESEARCH	36

11.2.8 HELP	36
12. DATABASE ACCESS PASSWORD	36
13. FUNCTIONING OF THE MULTICOMPONENT DOSAGE	37
13.1 FUNCTION OF THE ACTIVITIES AND THE FORMULAS	37
13.1.1 "AUTOMATIC DOSAGE" TYPE OF ACTIVITY	38
13.1.2 "MANUAL DOSAGE" TYPE OF ACTIVITY	38
13.1.2.1 FUNCTIONING WITH CONTROL LIGHT	40
13.1.3 "UNLOADING" TYPE OF ACTIVITY	41
13.1.3.1 NET/GROSS WEIGHT DISPLAY AT THE END OF UNLOADING ACTIVITY	44
13.1.4 "PAUSE" TYPE OF ACTIVITY	44
13.1.5 "TIMER" TYPE OF ACTIVITY	45
13.1.5.1 ALARM OUTPUT AND ACTIVATION MODE OF THE NEXT ACTIVITY	45
13.1.6 "MANUAL WEIGHT" TYPE OF ACTIVITY	46
13.1.7 "REMOTE DOSAGE" TYPE OF ACTIVITY	46
13.1.8 "SYNCHRONIZATION" TYPE OF ACTIVITY	46
13.1.9 FILTERING TIME	47
13.1.10 MAXIMUM DOSAGE TIME	47
13.2 FORMULA EXECUTION MODES	47
13.2.1 FORMULA WEIGHS	47
13.2.2 RECALCULATION OF WEIGHTS IN RESPECT TO FIRST FREE ACTIVITY	47
13.2.3 RECALCULATION OF WEIGHTS IN RESPECT TO TOTAL	49
13.2.3.1 TOTAL WEIGHT TO LOAD OVER THE MAXIMUM DOSABLE WEIGHT	49
13.2.3.2 ENTERING THE TOTAL WEIGHT	50
13.3 PROCEDURES OF THE DOSAGE CYCLE	50
13.3.1 DOSAGE CYCLE START	51
13.3.2 AUTOMATIC ACQUISITION OF THE TARE OR ZERO AT CYCLE BEGINNING	51
13.3.3 PAUSE – MOMENTARY INTERRUPTION OF THE DOSAGE CYCLE	51
13.3.4 DOSAGE CYCLE RESET	51
13.3.5 SETTING THE NUMBER OF DOSAGE CYCLES	52
13.3.6 QUICK CHANGE OF TARGET ACTIVITIES	52
13.4 TOLERANCE CHECK MODES	53
13.4.1 TOLERANCE EXPRESSED AS WEIGHT	53
13.4.2 TOLERANCE EXPRESSED AS PERCENTAGE OF WEIGHT	53
13.5 CORRECTION OF WEIGHT IN FLIGHT	54
13.6 MIN AND MAX LEVEL THRESHOLDS	54
13.7 PRODUCTION PROGRAM	54
13.8 FUNCTIONING OF THE REMOTE COMPONENTS' DOSAGE	55
14. PRINTOUTS	59
14.1 LINKING OF THE FORMATS TO THE PRINT FUNCTIONS	62
14.1.1 QUICK LINKING OF A SPECIFIC PRINT FUNCTION	64
14.2 TICKET PROGRESSIVE SETTING	64
14.2.1 PROGRESSIVE DIGITS	64
14.3 REPETITION OF THE LAST EXECUTED PRINTOUT	65
14.4 DEFAULT PRINTING FORMATS	65
14.5 STANDARD PRINTOUT EXAMPLES	66
15. OTHER FUNCTIONS	68
15.1 DIAGNOSTIC PERIPHERALS	68
15.2 COM DATA DIAGNOSTIC	68
15.3 CALCULATOR	69
15.3.1 HELP FUNCTION	69
15.4 DISPLAY OF NET WEIGHT WITH SENSITIVITY X 10 (for testing use during calibration)	69
15.5 SETTING DATE / TIME	69
15.6 CUSTOM DISPLAY	70
WARRANTY	71

1. INTRODUCTION

This manual was created to help you install and learn all about the functional possibilities of the purchased indicator.

The instrument is suitable for use in various weighing environments.

Not only does it have all the normal features of high-precision scales, but it also gives you the possibility to work in specific environments due to the functioning modes contained in the software implemented in the FLASH MEMORY on the internal board; This makes the instrument extremely flexible and it can be used in many different industrial applications linked to weighing. The double numerical and interactive alphanumeric display, the alphanumeric and function keyboard, allow the operator an easy and immediate use and provide the microcontroller with DATA ENTRY functions in addition to the normal weighing functions. The input/output allows the instrument to control various external devices, to receive external commands, control a printer and communicate with a personal computer or to be inserted in a network of weight indicators controlled by a PC.



Please note that this instrument is covered by a warranty and **MUST NOT BE OPENED BY THE USER** for any reason whatsoever. Any attempt to repair or modify the unit exposes the user to the risk of electric shock and will invalidate the entire warranty.

If any problems are found in the unit or with the system in which it is used, the fact must be communicated to the manufacturer or the dealer from whom it was purchased.

In any case, **DISCONNECT THE POWER SUPPLY** before taking any action.

With the 6V rechargeable battery version, it has to be completely recharged (12 hours) in the first installation of the instrument; we RECOMMEND disconnecting the battery if the instrument is not going to be used for more than 30 days. In order to avoid the deterioration of the rechargeable battery:

- In standard conditions, never leave the battery partially or completely uncharged; at least once a week recharge it completely.
- In case the instrument is not used for a long period, one needs to
 1. completely recharge the battery before the system is switched off for the last time;
 2. recharge completely every 3 months.

Do not pour liquids on the weight indicator.

Do not use solvents to clean the weight indicator.

Do not expose the instrument to direct sunlight nor place it near heat sources.

Place or anchor the weight indicator and platform on a non-vibrating base.

All the connections of the indicator have to be made respecting the rules applicable in the zone and in the installing environment.

Read carefully and apply what is described in chapter 3.

Do not install in any area where there is a risk of explosion.



The crossed-out wheeled bin on the product means that at the product end of life, it must be taken to separate collection or to the reseller when a new equivalent type of equipment is purchased. The adequate differentiated refuse collection in having the product recycled, helps to avoid possible negative effects on the environment and health and supports the recycling of the materials of which the equipment is made. The unlawful disposal of the product by the user will entail fines foreseen by the current regulations.

2. MAIN TECHNICAL SPECIFICATIONS

POWER SUPPLY	<p>3590E:</p> <ul style="list-style-type: none"> - 12 Vdc, with internal 100 ÷ 240 Vac (50÷60 Hz) / 12 Vdc power adapter. - 6 Vdc from rechargeable built-in battery, fitted depending on the model. <p>CPWE:</p> <ul style="list-style-type: none"> - 8 ÷ 36 Vdc - 6 Vdc from external rechargeable battery (upon request). <p>CPWETF:</p> <ul style="list-style-type: none"> -8 ÷ 36 Vdc -110-240Vac Vac power supply through built-in power adapter.
MAXIMUM POWER	16 VA.
OPERATING TEMPERATURE	From -15 to +40 °C.
CONVERTER	24 bit Sigma Delta.
CONVERSION SPEED	200 conv./sec with automatic selection.
RANGE OF INPUT SIGNAL	0,6 mV/V - 3,2 mV/V.
MINIMUM VOLTAGE PER DIVISION	0.3 µV (approved instrument); 0.3 µV (non-approved instrument).
AUTOMATIC ZERO DETECTION	Only in gross mode, programmable at +/- ¼, ½, 1, 2 divisions.
ZERO RANGE	Configurable up to +/- 50% of max load capacity.
AUTO ZERO AT START-UP	Configurable up to +/- 50% of max load capacity.
LOAD CELL POWER SUPPLY	5Vdc ± 5%, 120mA (max 8 350-Ohm cells).
LOAD CELL CONNECTIONS	6 wires with Remote Sense.
DISPLAY DIVISIONS	10000e, 3 x 3000e for legal for trade weighing, expandable up to 800.000 for internal use (with minimum signal coming from the 1,6 mV/V cell).
DISPLAYS	<p>3590E:</p> <ul style="list-style-type: none"> - Red, high-luminosity LED indicators, with six digits (h 13 mm). - Back lit graphic 160x32 dot LCD. <p>CPWE: Back lit graphic 160x32 dot LCD.</p>
TARE FUNCTION	Subtractive possible on the entire capacity.
DATABASE/MEMORY	Database of 500 formulas, 100 activities and 15 free texts.
SIGNALS	<p>3590E: 16 status LEDs. Graphic icons on LCD display.</p> <p>CPWE: Graphic icons on LCD display.</p> <p>CPWETF: Fitted with 3-way control light.</p>
KEYBOARD	Impermeable polycarbonate keyboard, with membrane keys having an audible and tactile feedback.
PARAMETER SETUP	Calibration and linearity (up to 8 points), fully digital and programmable from the keyboard or from PC with Dinitools™.
CLOCK/DATE	Fitted, with buffer RAM.
CASE	<p>3590E: IP68 Stainless steel case.</p> <p>CPWE: Anodized aluminium case with IP65 front panel protection.</p>
SERIAL OUTPUTS	<ul style="list-style-type: none"> - 2 input/output RS232 ports on terminal board/ amp connector. - 1 input/output RS485 port on terminal board or RS232 on amp connector.
INPUTS AND OUTPUTS	<ul style="list-style-type: none"> - 8 inputs (optoisolated photo couplers), 12Vdc – 24Vdc, 20mA max. - 16 outputs (optoisolated photomofets), 48Vac / 0.15A, 60Vdc / 0.15A. - Management of the PC keyboard, bar code reader.
ANALOGUE OUTPUT (OPTIONAL)	16 BIT, settable on the net or gross weight or to the dosage speed; the maximum resistance applicable on the output current is 350 Ohm and the minimum resistance applicable on the output voltage is 10 kohm.

2.1 ACCESSORIES AVAILABLE







The indicator can be implemented with additional internal and external modules used to increase interfacing possibilities. For example one can connect various types of printers (in order to have an outcome of the weighs carried out). Also, one can connect a PC temporarily in order to simply program the instrument through Dinitools™, or permanently in order to have a complete management of the weighs.

Contact the reseller for the list of the available hardware and software accessories.

2.2 SYMBOLS

Below are the symbols used:

- in the manual to recall the reader's attention
- on the instrument to recall the user's attention

	ATTENTION! Only qualified personnel must perform this operation
	ATTENTION! This is referred to working on energized lines: only qualified personnel must require or perform this operation.
	CE CONFORMITY
	IDENTIFIES THE CLASS OF PRECISION.
	IDENTIFIES THE ABBREVIATION OR THE NAME OF THE STEP OF THE TECHNICAL SET-UP, TECH.MAN.REF.
	It means that an advanced function is being described (therefore for the technical personnel) which will be further explained in the corresponding technical manual.

THE INSTRUMENT'S DANGEROUS VOLTAGE PARTS AND THE PARTS THE USER CAN ACCESS HAVE BEEN ELECTRICALLY INSULATED.

3. INSTALLATION

3.1 CPWE DRILLING TEMPLATE, CASE AND DIMENSIONS

The weight indicator has an anodized aluminium case, whose external dimensions are shown in the figure. It should be mounted on a panel board respecting the safety norms.

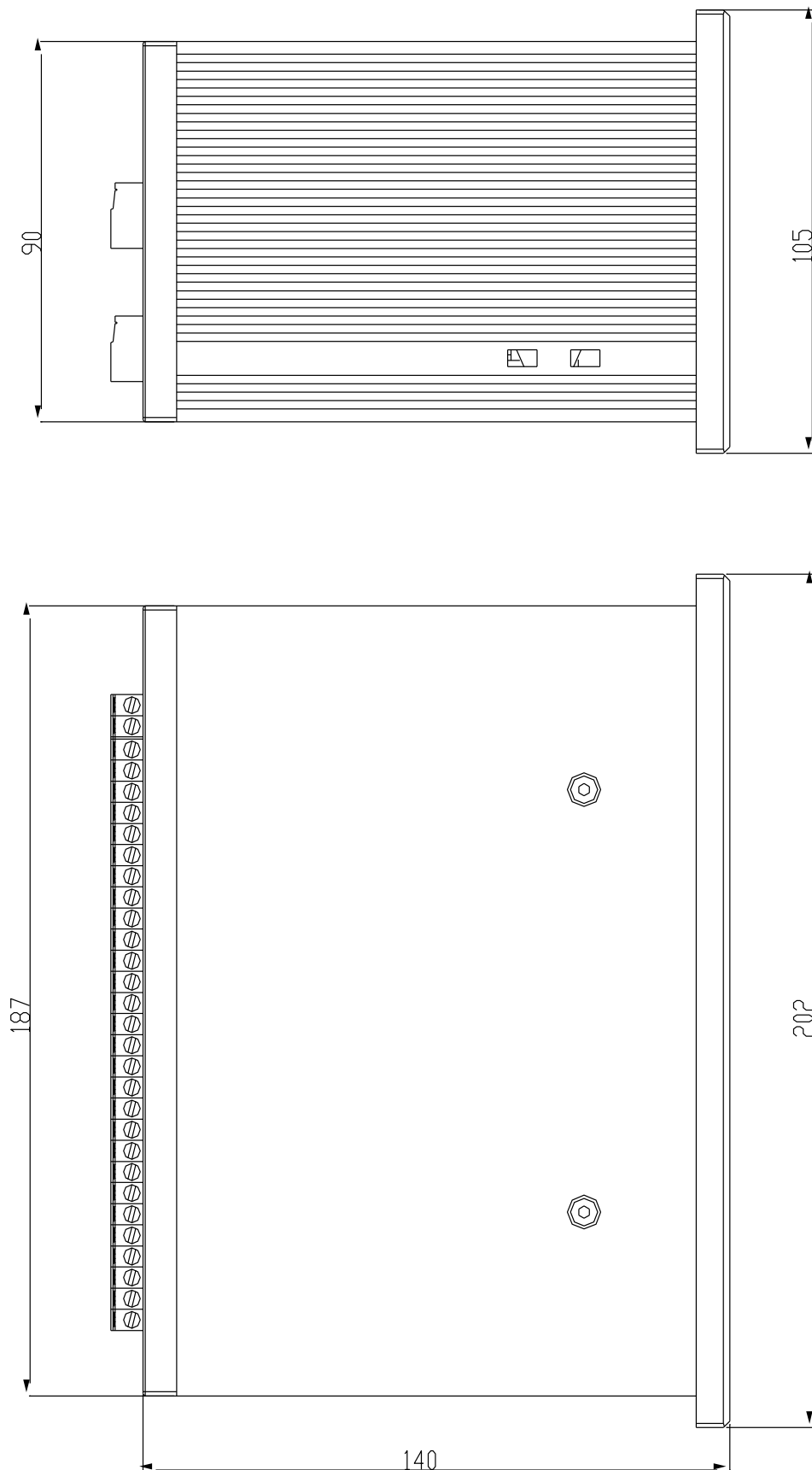

Figure 1: DRILLING TEMPLATE DIMENSION: 187,5mm x 91,5mm

3.2 3590E CASE AND DIMENSIONS

STAINLESS STEEL MODEL

The indicator has a STAINLESS STEEL case, whose external dimensions are shown in the Figure 2. It can be simply put on a table or fixed to a shelf or column available on request.

NOTE: If the identification plate is supplied separately (therefore not attached to the indicator), it is advisable to attach it to the indicator, in order to be able to identify the instrument.

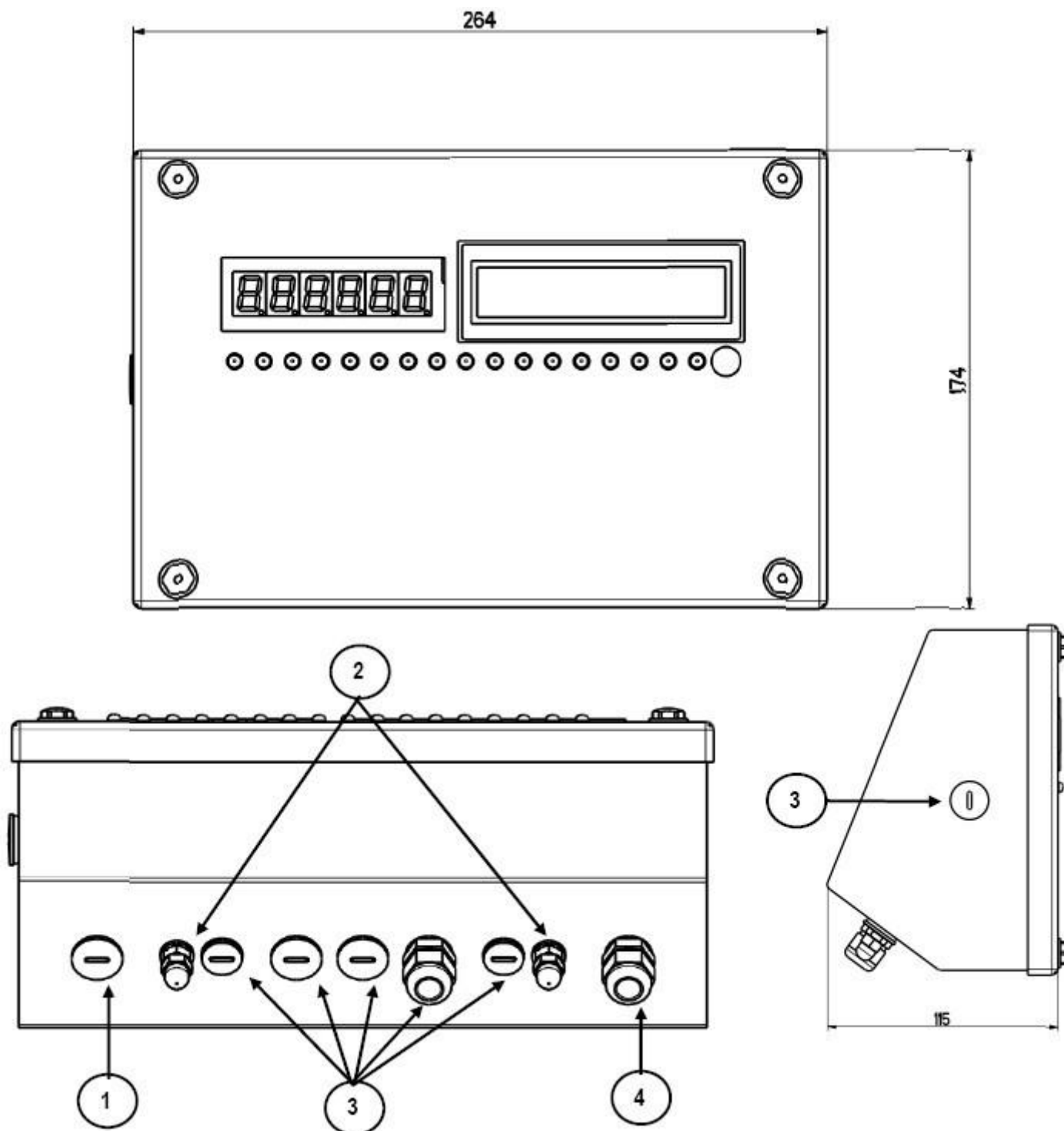

Figure 2 – Measurements and dimensions in mm

- 1) RJ45 connector
- 2) Fixing for shelf or column mounting
- 3) Available for load cells / serial lines / inputs / outputs.
- 4) Power supply input.

3.3 CPWETF CASE AND DIMENSIONS

The weight indicator has a STAINLESS STEEL case, whose external dimensions are shown in figure 5. The instrument may be installed on the wall.

NOTE: If the identification plate is supplied separately (therefore not attached to the indicator), it is advisable to attach it to the indicator, in order to be able to identify the instrument.

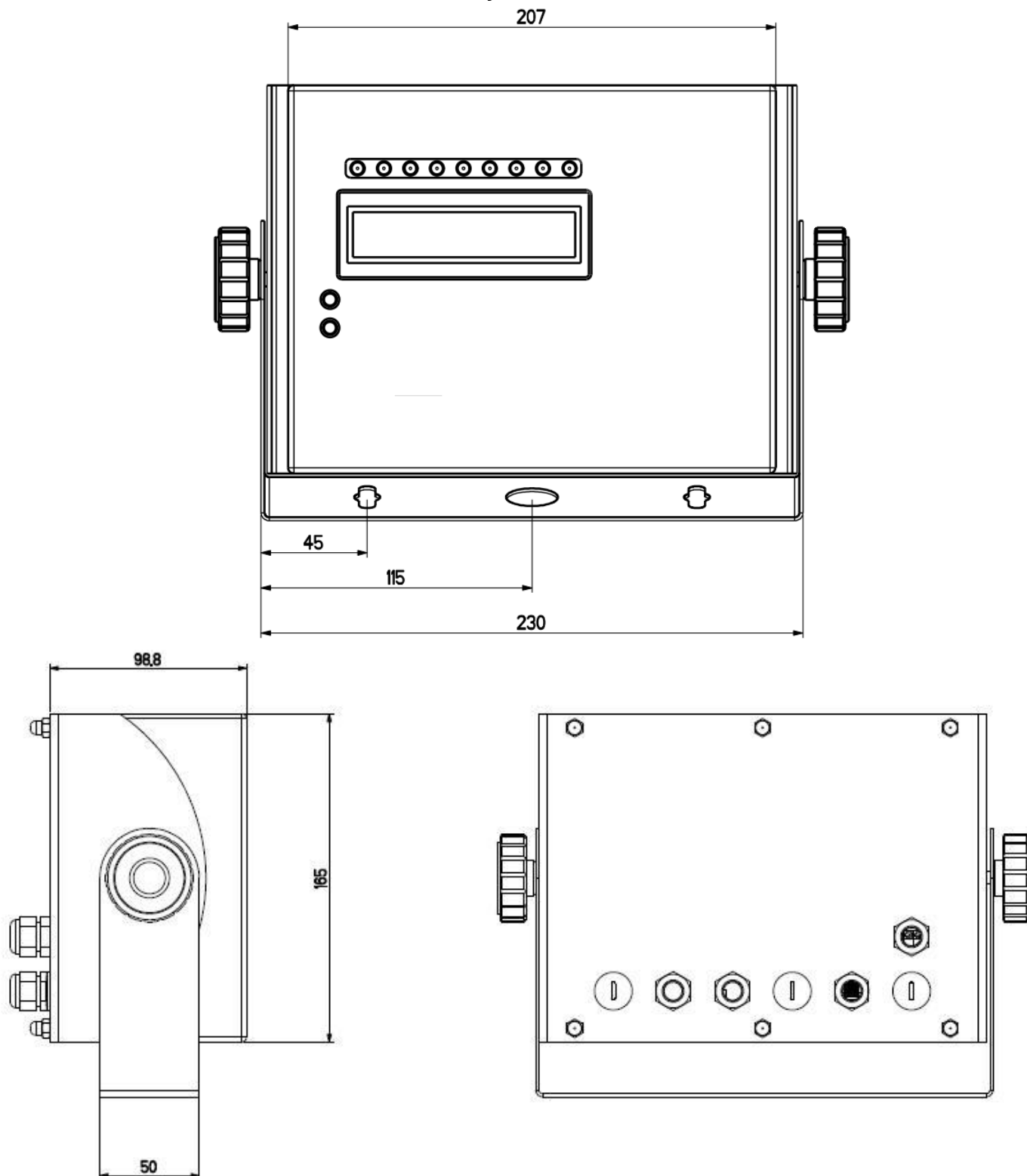

Figure 5 – Measurements and dimensions in mm

- 1/2) Available for load cells / serial lines / inputs / outputs
- 3) Power supply input.
- 4) RJ45 connector

3.4 POWER SUPPLY & START UP

- The 3590E indicator is powered with 12Vdc voltage, through an internal adapter which converts the 100 ÷ 240Vac, 50÷60Hz mains voltage.

TO POWER the instrument through the 240 Vac mains, insert the plug and the adapter to the 240 Vac mains socket.

- The CPWE indicator is powered with 8÷36 Vdc voltage.
- The CPWETF indicator is powered with 8÷36 Vdc voltage.

For the connection to the power supply mains, the safety norms must be respected including the use of a “clean” line without noise and interference caused by other electronic devices.

Do not connect other equipment to the same socket as the one that the adapter is in.

Do not step on or crush the power supply cable

TO TURN ON the 3590E or CPWETF press the C key until the display turns on; then release.

The CPWE instead is automatically turned on as soon as it is powered.

The display shows:

- Initially a welcome message (settable in the TECHNICAL SET-UP, << LoGo >> StEP, TECH.MAN.REF) while the instrument carries out a series of checking and preheating self tests.
- BATCH - XX name of the installed software, in which XX identifies the software language.
XX.YY is the software version installed.
- BATCH - XX name of the installed software, in which XX identifies the software language.
BARGRAPH
- “EXECUTION AUTOZERO”

The instrument carries out the "autozero at start-up" function: if a weight is detected within the percentile set in the << **Auto-0** >> step (TECH.MAN.REF.), it is cleared; if the weight is not within this tolerance:

- with a non approved instrument, the display shows the weight after a few instants,
- with an approved instrument, the message “EXECUTION AUTOZERO” appears continuously on the display, until the weight is within tolerance.

The autozero function at start-up can be disabled in the set-up environment (only with a non approved instrument), see the <<**Auto-0**>> parameter.

By pressing the **2ndF** key while the version is shown in the display, the indicator shows in sequence:

- | | |
|--------------------|--|
| 01.01 | in which 01 indicates the instrument type, 01 indicates the metrological software version. |
| XX.YY.ZZ | is the installed software version. |
| HH | is the installed hardware version (08). |
| LEGAL FOR TRADE | |
| or HIGH RESOLUTION | if the instrument is APPROVED or UNAPPROVED, respectively. |
| 9.XXXXX | is the g gravity value (only with APPROVED instrument). |

TO TURN OFF the 3590E or the CPWETF, or **TO RESTART** the CPWE keep the C key pressed until the “- OFF -” message appears on the LED display and “ *** POWER OFF *** ” on the LCD display.

TO TURN OFF the CPWE remove the instrument’s power supply

3.5 CONNECTION TO THE BATTERY POWERED PRINTER

In a system where the indicator is connected to a printer, and both are battery powered, the printer is normally maintained in STAND-BY and powered only when a printout is needed. This function reduces the energy absorbed by the battery when the printer is not being used.

If, in this configuration, one should power the printer to change the paper and other maintenance jobs, one needs to keep pressed the **ENTER** and **0** keys (outside the dosage cycle): the display shows **Prn - on**, and the printer is kept on. Press any key to exit from this condition.

4. FUNCTION PANEL KEYS

3590E

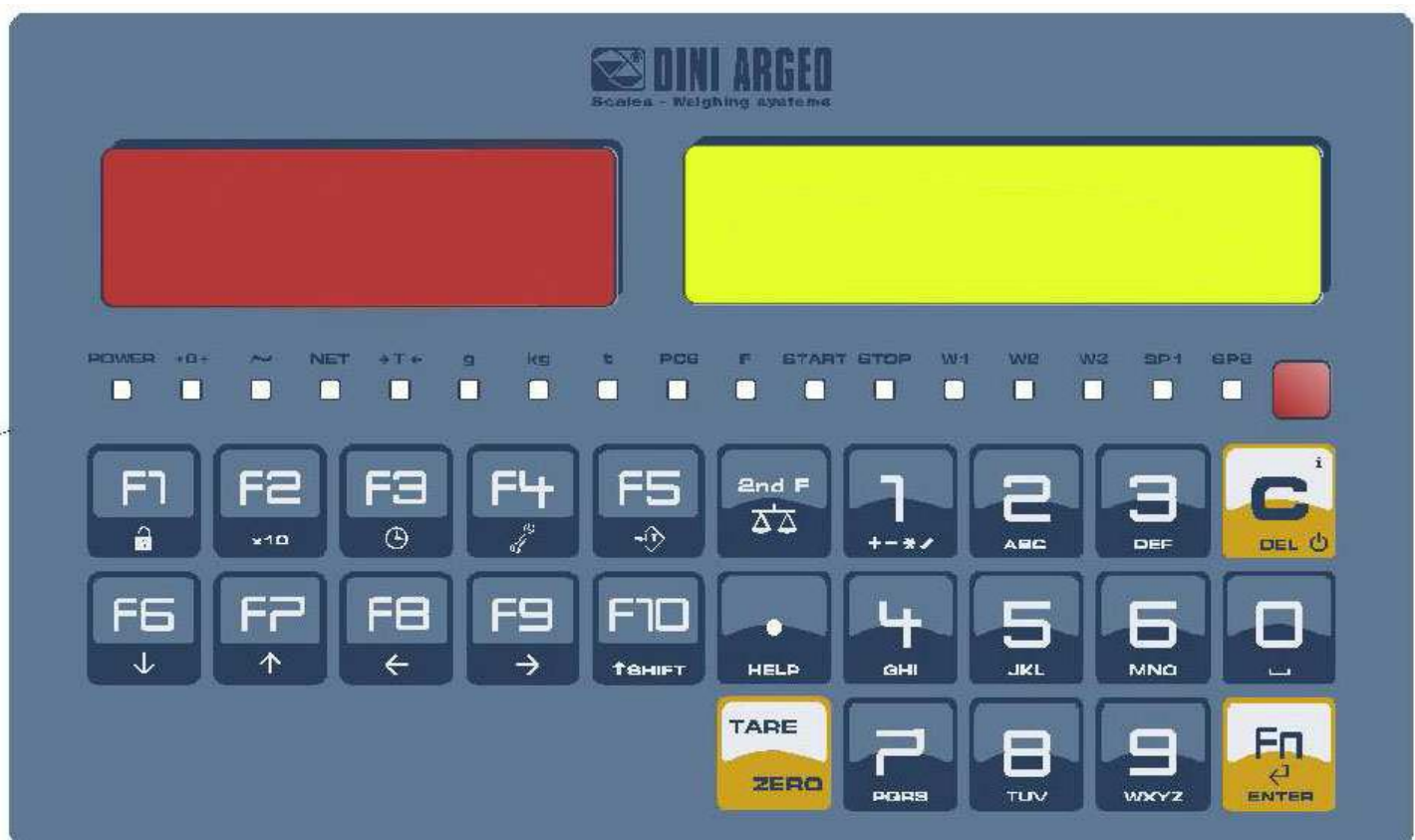

CPWE



CPWETF



4.1 FUNCTION OF THE KEYS

In the following section, and later on in the manual, the keys' functioning is described in accordance to how these are configured by the factory. It is possible to customise the functionality of the keys through the << **F.KEYS** >> step.

KEY	FUNCTION
C / DEL	<ul style="list-style-type: none"> - If pressed for an instant, it clears the tare value. - If pressed at length it restarts the instrument. - Exits the parameter without confirming and saving the modifications. - In the numeric input phase, it quickly clears the present value.
TARE/ ZERO	<ul style="list-style-type: none"> - If pressed for an instant it carries out the semiautomatic tare, or cancels the tare value if the gross weight is 0. - If pressed at length, it clears the displayed gross weight, if it's within the percentage configured in the << 0.PErC >> step.
Fn / ENTER	<ul style="list-style-type: none"> - In the alphanumeric input phase, it confirms the entry made. - In the menu it allows to enter a step or to confirm a parameter inside a step.
2nd F	<ul style="list-style-type: none"> - If pressed together with the other keys, it allows carrying out a specific function. (see section 4.1.1).
. / HELP	<ul style="list-style-type: none"> - If pressed in some steps or functions of the weight indicator, the display shows the keys and their specific functions to that state of the instrument. - In the numeric or alphanumeric input phase, it enters, in this order, the following characters: . , ; : # < > \ " % & / () = ? ^ ' [] { }; - "HELP MENU" function, see section 4.1.4.
F1	<ul style="list-style-type: none"> - By entering a number through the numerical keyboard and then pressing the F1 key, one can quickly select the article corresponding to the entered value (the article must have already been edited). - In the numeric or alphanumeric input phase, it allows to copy entered characters. - If pressed for an instant, it enters into the formulas' database. - If pressed at length, it locks and unlocks the instrument's keyboard (except the C key).
F2	<ul style="list-style-type: none"> - In the numeric or alphanumeric input phase, it allows to stick with copied characters. - If pressed for an instant, it enters into the activities' database. - If pressed at length, the weight visualisation function with sensitivity x 10 is enabled
F3	<ul style="list-style-type: none"> - If pressed for an instant, it allows to change quickly the target of each activity of a formula - If pressed at length, one can adjust the date and time of the instrument.
F4	<ul style="list-style-type: none"> - If pressed for an instant, it allows to fill in the free texts, if configured - If pressed at length, it enters the instrument's diagnostics menu.
F5	<ul style="list-style-type: none"> - it commands the data transmission to the printer serial port. - If pressed at length, it locks/unlocks the tare.
F6	<ul style="list-style-type: none"> - It allows scrolling ahead inside the menu steps or in the parameters within a step. - In the numeric or alphanumeric phase, it decreases the blinking digit. - Start dosage
F7	<ul style="list-style-type: none"> - It allows scrolling backwards in the menu steps or in the parameters within a step. - In the numeric or alphanumeric input phase, it increments the blinking digit. - It allows to insert the formula's target (see section 13.2.2).
F8	<ul style="list-style-type: none"> - It allows to insert the number of cycles - In the numeric or alphanumeric input phase, it selects the digit to be modified from right to left.
F9	<ul style="list-style-type: none"> - If pressed for an instant, it executes the printing and the zeroing of the general total. - In the numeric or alphanumeric input phase, it selects the digit to be modified from left to right.
F10	<ul style="list-style-type: none"> - Stop dosage. - In the numeric or alphanumeric input phase, introduces a space between two characters.
NUMERIC KEYBOARD	<ul style="list-style-type: none"> - Entry of digits or characters. - While weighing, these enter a numeric value with which it's possible to: <ol style="list-style-type: none"> 1) Set the tare value, by pressing subsequently the TARE key (see section 7.2). 2) Execute calculations (see section 15.3 - "CALCULATOR").

4.1.1 "2ndF" KEY: SECOND FUNCTION OF THE KEYS

In the weighing phase, by pressing the **2ndF** key together with another key, it's possible to execute various functions (continue reading the manual for the details of the functions):

2ndF	F1	Print/Clearing of total of formula.
2ndF	F2	Print/Clearing consumption dosage activity.
2ndF	F5	Repetition of the last printout made.
2ndF	F8	Net/Gross Conversion.
2ndF	F9	Modification of the data shown on the second line info on CPWE/CPWETF or first line of LCD display on 3590E (see section 4.2.4).
2ndF	F10	Modification of the data shown on the first line info on CPWE/CPWETF (see section 4.2.4).

4.1.2 ENTERING ALPHANUMERIC TEXT

It might be necessary, while the weighing system is working, to enter some alphanumerical texts such as descriptions, alphanumerical messages (operator, lot number, customer, etc.).

To enter the characters one uses the **0** to **9** keys.

By pressing one of these keys a few times, the characters shown on the key will be shown on the display: initially the first letter in the bottom left will appear, and then the other characters towards the right.

After digiting a character, the blinking cursor, after a few instants, advances automatically of a position.

Function of the keys

- F5** switches the writing mode from "numeric" (**nuM**) to "characters" (**ChAr**).
In the **nuM** mode one enters just the numbers, while in the **ChAr** mode one can enter all the characters of a key.
- C** If pressed for an instant, it cancels the written characters: first the characters that follow the cursor are cancelled; than those that precede it, one at a time.
If pressed at length, it deletes all entered characters.
With empty text, it exits the entry phase without confirming.
- SHIFT** It enters a space in the middle of a text.
- ./HELP** If pressed a few times it allows entering the following characters: . , ; : # < > \ | " ' % & / () = ? ^ ' [] { }
- 0** in "characters" mode (**ChAr**), by pressing once **a space is entered**; by pressing twice it enters the "0" character;
- 1** in "characters" mode (**ChAr**), pressed repeatedly, it allows to enter the following symbols:
? ! 1 @ ' + - * / = ~ € „ … † ‡ ^ % ¢ š < OE ž Ĩ ' " • - - ~ ™ Š > oe ž ¢ £ ¤ ¥ ¦ § ¨ © ª « ¬ - ® ¯ ° ± ² ³ ´ μ ¶ · ¸ ¹
º » ¼ ½ ¾ ĩ ã
- ◀ ▶ moves the blinking cursor to the left or to the right.
- ▲ ▼ scrolls in one sense or the other the list of all the enterable characters (0, 1...9, A, B...Y, Z)

Examples:

- To enter the letter "B" one should press the "2" key twice in the **ChAr** mode.
- To enter the number "3" one should press the "3" key four times (in the **ChAr** mode) or press the F5 key (one passes to the **nuM** mode) and press the "3" key once.

4.1.3 DISABLING THE KEYBOARD

It is possible to disable all the keyboard functions (except the **C** key for turning on and off), in order to avoid undesired pressings of the scale keys:

- **To lock the keyboard**, press at length the **F1** key: the display shows the “LoCK” message for a few instants. Now the keyboard is LOCKED: if one presses a key, the display shows for a few instants the “PRESS AT LENGTH F1 FOR UNLOCKING” message.
- **To unlock the keyboard**, press again at length, the **F1** key: the display shows the “unLoCk” message for a few instants.



NOTE: It's possible to lock all keys individually in a permanent way through the TECHNICAL SET-UP, **TECH.MAN.REF.**

4.1.4 HELP MENU

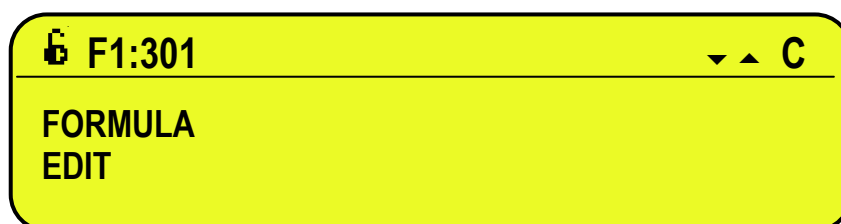

By pressing at length the **HELP** key it is possible to access a menu containing the list of keys with the relative function, and status (locked or unlocked) indication.

The display shows:



- in the upper part: the key, followed by the code of the linked function in the << **F.Keys** >> step, and a symbol indicating whether the key is unlocked () or locked () in the << **EN.KEYS** >> step.

- in the lower part: the description of the linked function. 

Scroll the list with the arrow keys  , press the **C** key to exit.

4.1.5 INDICATOR CONNECTED TO REMOTE KEYBOARD

It's possible to connect a PC keyboard (optional), used to emulate the functions of the keys of the indicator.

The keys are managed in the following way:

Esc	- C key. - If pressed at start-up, it allows entering in the technical set-up. In the alphanumeric input, it deletes all entered characters.
← and Canc	- C key. - If pressed at start-up, it allows entering in the technical set-up. In the alphanumeric input, it cancels first the characters which follow the cursor, then the ones which precede it, one at a time.
Enter ↵	- Fn key. - Confirms the entered value. - Enters the displayed step
Numeric and alphanumeric keys, SHIFT and CAPS LOCK	- Quick entry of a numeric and alphanumeric string: through the CAPS/LOCK or SHIFT key it is possible to switch from the capital letters to the lower case letters, and vice versa, or enter the second character corresponding to the key (for example ", %, &, /, ?)
Cursor keys ↑ ↓	- Scroll the parameters - Increase or decrease the blinking digit while entering a value.
Cursor keys ← →	- When entering a value or an alphanumeric string, it scrolls the digits to the right or to the left.
F1, F2....F10	F1,F2....F10 keys.
F11	2ndF key
F12	TARE key.

NOTE: through the remote keyboard, it's not possible to carry out the functions made by pressing the keys at length.

4.2 DISPLAY FUNCTIONS

While weighing, the display is subdivided mainly in 4 sections, shown in the figure below:

- 1) WEIGHT or PROGRESS BAR for the remote dosage function.
- 2) STATUS INDICATORS (led pilot lights / or graphic symbols), see section 4.2.2.
- 3) SELECTABLE INFO (one line in the 3590E; one or two lines in the CPWE/CPWETF, depending on the weight zoom function, see following section), see section 4.2.4.
- 4) SYSTEM STATUS INFO, see section 4.2.5.

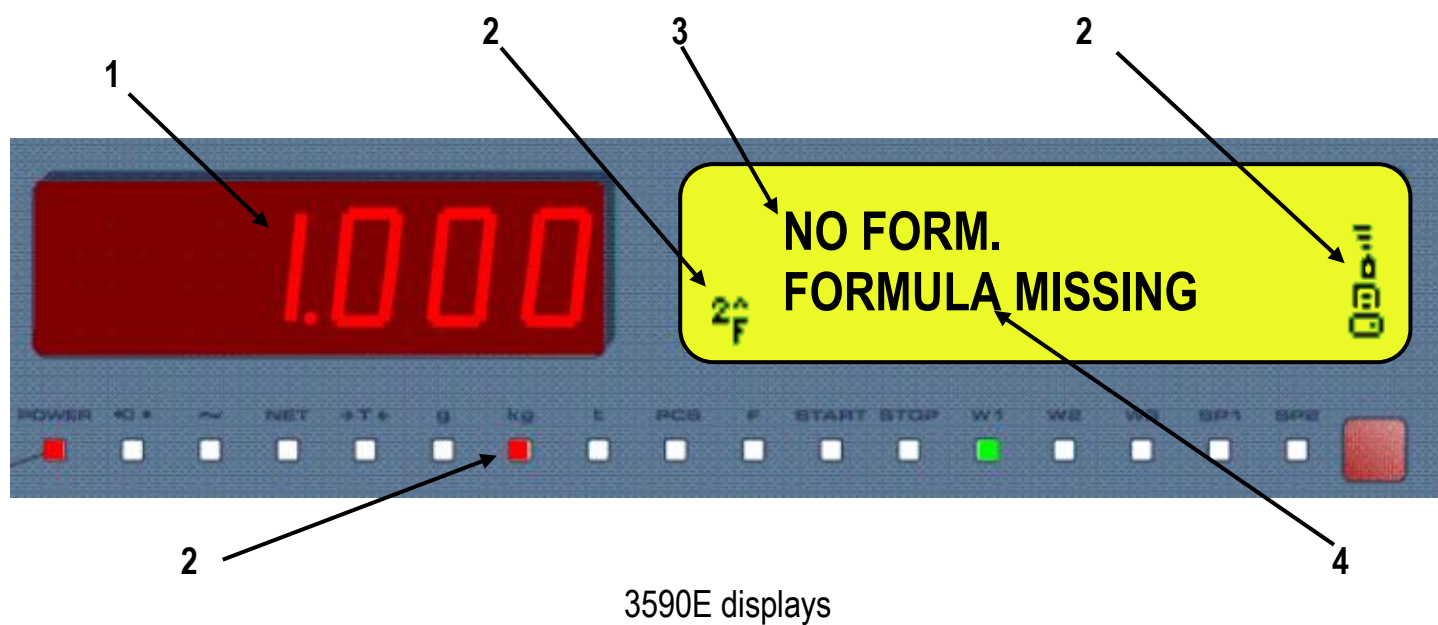
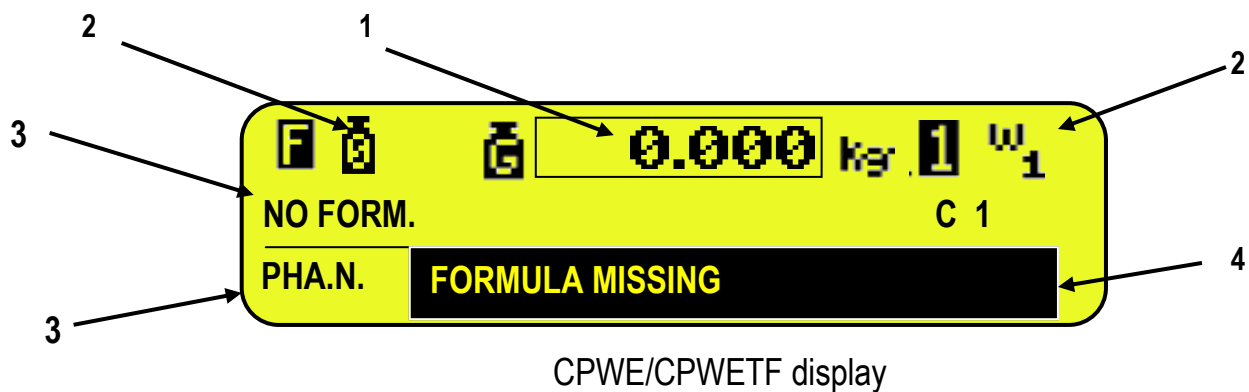

In dosage:

- 1) Number of dosag cycle.
- 2) Phase of the executing activity. See section 13.1 for further details.
- 3) Target to be dosed.

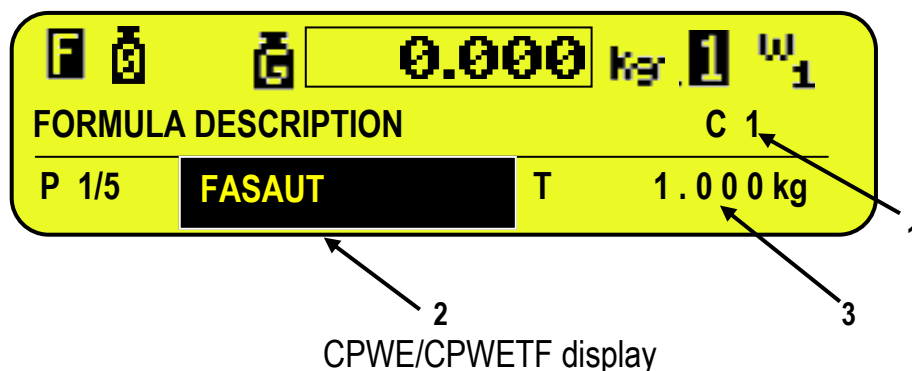

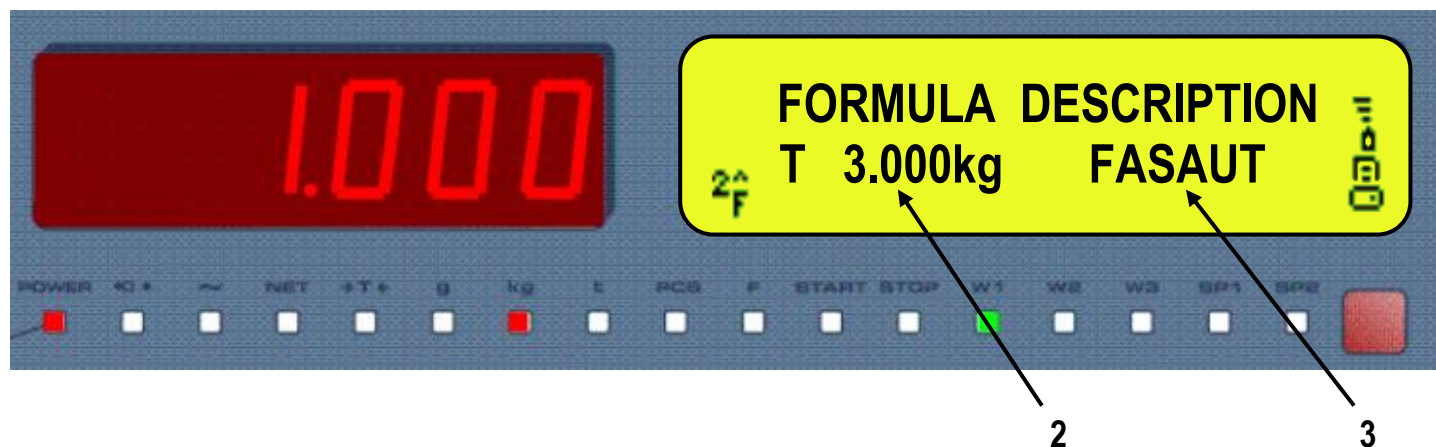

3590E displays

NOTE: If the EEEEE message appears, this means that the value exceeds the maximum number of digits shown by the instrument.

4.2.1 WEIGHT ZOOM

The zoom function allows to increase the size of the weight digits, in order to ease the reading from a distance; with the active zoom, only the second line info is shown (see section 4.2.4).



CPWE/CPWETF display

In dosage:

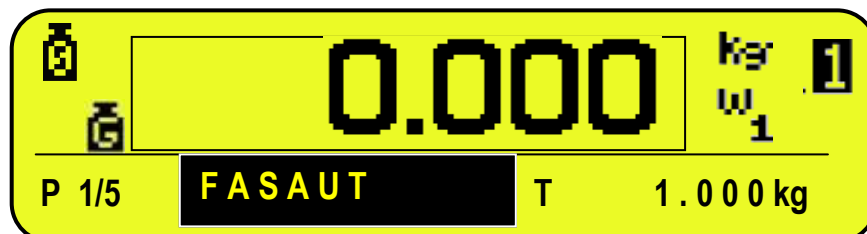











CPWE/CPWETF display

Through the << **ZOOM.W** >> step, one can disable/enable the function and set a delay which determines the activation mode:

- always active function (with delay equal to 0), or
- disabled function at the pressing of a key and reenabled automatically when the keyboard inactivity time reaches the configured delay period (with delay greater than 0).

4.2.2 STATUS INDICATORS – 3590 Model

LED	FUNCTION
POWER	Indicates the type of indicator power supply: red pilot light: through built-in power adapter; green pilot light: through battery (charged battery); pilot light off: through battery (discharged battery).
→0←	Indicates that the weight detected by the weighing system is near zero, including the interval of $1/4$ $+1/4$ of the scale's division.
~	Indicates that the weight is unstable.
NET	Indicates that the weight shown by the display is a NET WEIGHT.
→T←	Indicates that a tare value has been acquired or entered.
g	Indicates that the unit of measure in use is the gram.
kg	Indicates that the unit of measure in use is the kilogram.
t	Indicates that the unit of measure in use is the ton.
PCS	Not used in application
F	Indicates that an activity is finished correctly.
START	Indicates that the dosage has started.
STOP	Indicates that system is out of dosage.
W1 W2 W3	See section 8.
SP1	Not used in application
SP2	Not used in application

SYMBOL ON LCD DISPLAY	FUNCTION
	The weight detected by the weighing system is near the zero, included within the interval of $-1/4$ and $+1/4$ of the scale division.
	The weight is unstable.
	The displayed weight is a GROSS WEIGHT (depending on the software language).
	The displayed weight is a NET WEIGHT.
	A tare value has been acquired.
	A manual tare value has been entered.
	Unit of measure in use: ton, kilogram, gram, pounds, millilitres, or millivolts.
	Active weighing range, see section 8.
	Active scale or remote dosage enabling.
	Indicates that a specific function of the instrument is active.

4.2.4 SELECTABLE INFO







Some data shown on the display can be modified by selecting one of the various visualisations provided for by the indicator.

CPWE/CPWETF

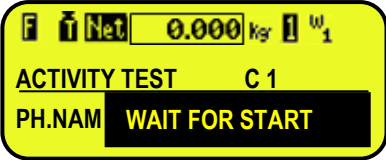
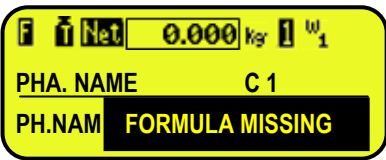
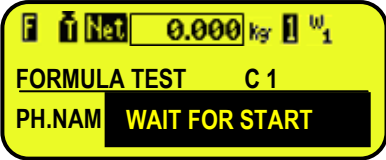
The selectable info is shown on two lines under the “weight” section. It is possible to modify independently the visualization of both lines. The first line is shown only with non active weight zoom (see section 4.2.1).

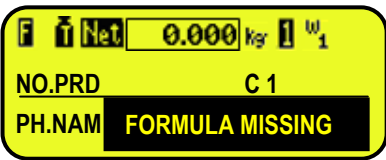

SELECTION OF THE FIRST LINE INFO

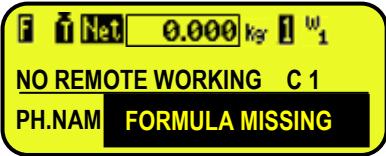
By pressing in sequence the **2ndF** and **F10** keys, one will change the first line info, scrolling in order the following visualisations:

NUM.	FIRST LINE VISUALISATION	WITH SELECTED FORMULA, PRODUCTION PROGRAM OR REMOTE COMPONENTS	WITHOUT SELECTED FORMULA, PRODUCTION PROGRAM OR REMOTE COMPONENTS
0	During dosage, it indicates description of present active activity.		
1	Description of selected formula.		
2	Total weight of selected formula.		
3	Total weight of selected production program.		
4	During dosage, it indicates 485 address number of the remote instrument		

SELECTION OF THE SECOND LINE INFO

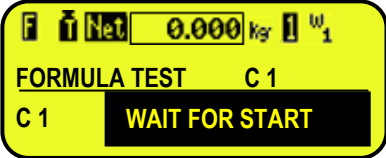
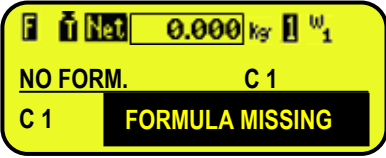
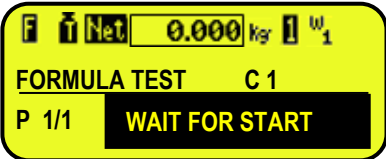
By pressing in sequence the **2ndF** and **F9** keys, one will change the second line info, scrolling in order the following visualisations:

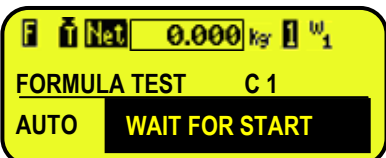
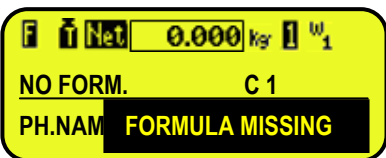
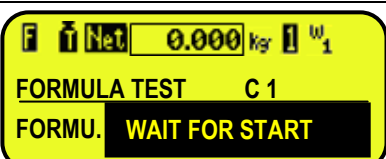
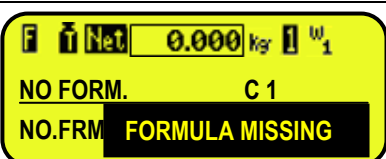
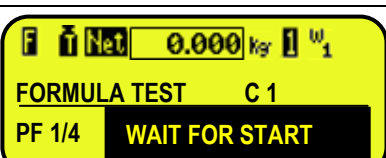
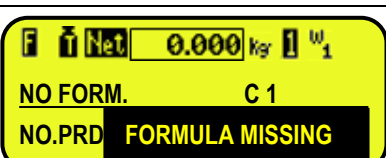
NUM.	SECOND LINE VISUALISATION	WITH SELECTED FORMULA, PRODUCTION PROGRAM OR REMOTE COMPONENTS	WITHOUT SELECTED FORMULA, PRODUCTION PROGRAM OR REMOTE COMPONENTS
0	Number of cycle dosage.		
1	During dosage, it indicates the number of activity that is being carried out.		
2	During dosage, it indicates the description of the active activity.		
3	During dosage, it indicates the description of selected formula.		
4	During dosage, it indicates the number of formula that is being carried out.		

By linking the 2 functions to a direct key, see the << **F.KEYS** >> step, it is possible to quickly recall a visualisation by digiting, with the numeric keyboard, the relative number and pressing the key linked to the function.

Furthermore, by linking the number of a specific visualization to the function (preamble function in the << **F.KEYS** >> step), it is possible to select it directly with a direct key, for example F1 key to select the visualization n.1, and F2 key to select the visualization n. 2.

NOTES

- Default visualisation: 1.

- if in the place of formula total, the EEEEE message appears, this means that the value exceeds the maximum number of digits shown by the instrument.

3590E

The selectable info are shown in the first line of the LCD display; by pressing in sequence the 2nd F and F9 keys, one scrolls in order the following visualisations:

NUM.	FIRST LINE VISUALISATION	WITH SELECTED FORMULA, PRODUCTION PROGRAM OR REMOTE COMPONENTS	WITHOUT SELECTED FORMULA, PRODUCTION PROGRAM OR REMOTE COMPONENTS
0	Total weight of selected formula.	FT 379.1kg WAIT FOR START	FORMULA MISSING
1	During dosage, it indicates the number of activity that is being carried out.	P 1/1 C 1 WAIT FOR START	PHASE N. C 1 FORMULA MISSING
2	During dosage, it indicates the description of the active activity.	AUTO C 1 WAIT FOR START	PHA.NAME C 1 FORMULA MISSING
3	Description of selected formula and number of cycle dosage.	FORMULA TEST C 1 WAIT FOR START	NO FORM. C 1 FORMULA MISSING
4	During dosage, it indicates the number of formula that is being carried out.	PF 1/2 C 2 WAIT FOR START	NO.PRD C 1 FORMULA MISSING
5	Total weight of selected production program.	PT 23.5kg WAIT FOR START	NO PRODUCTION FORMULA MISSING
6	Description of selected formula and number of cycle dosage. During dosage, it indicates the description of the active activity.	FORMULA TEST C 1 WAIT FOR START	NO FORM. C 1 FORMULA MISSING
7	Description of selected formula.	FORMULA TEST WAIT FOR START	NO FORM. FORMULA MISSING
8	During dosage, it indicates 485 address number of the remote instrument	01 02 WAIT FOR START	NO REMOTE WORKING FORMULA MISSING

By linking the function to a direct key, see the << F.KEYS >> step, it is possible to quickly recall a visualisation by digiting with the numeric keyboard, the relative number and pressing the key linked to the function.

Furthermore, by linking the number of a specific visualization to the function (preamble function in the << F.KEYS >> step), it is possible to select it directly with a direct key, for example F1 key to select the visualization n.1, and F2 key to select the visualization n. 2.

Notes:

- Default Visualisation: 7.

4.2.5 SYSTEM STATUS INFO

Below there are the statuses shown on the display, in the black box on the CPWE/CPWETF or on the second line on the 3590E.

STATUS	DESCRIPTION
FORMULA MISSING	No formula has been selected. Select the formula to be executed, see section 11.2.2.
FIRST ACT. ERR.	Error in the programming of the first activity, in the "FIRST FREE COMPONENT" functioning mode: the first activity of the formula must be a manual dosage or a manual weight. See section 13.2.2.
DOS + GROS > CAPAC	The gross weight on the scale, summed to the formula target, exceeds the scale capacity. Check the parameter (<<MAX.WGT>> step, TECH.MAN.REF) or diminish the gross weight on the scale.
FORMULA WEI. ERR	A target = 0 has been entered in the formula, or, in the "RECALCULATION OF THE FORMULA WEIGHTS IN RESPECT TO THE TOTAL" (<<EXE FOR>> step, <<TOT.WGT>> parameter, TECH.MAN.REF.), the maximum weight to be dosed has not been entered (see section 13.2.3).
0 WEIGHT FORMULA	In the "RECALCULATION OF THE FORMULA WEIGHTS IN RESPECT TO THE TOTAL" (<<EXE FOR>> step, <<TOT.WGT>> parameter, TECH.MAN.REF.) a target = 0 has been entered in the formula.
PHA. XX ERROR	If a selected activity doesn't exist or its type is invalid, the display shows this error message, in which XX is the activity number among all those linked to a formula.
NUM. PH ERROR	If the quantity of entered activity is wrong in the formula, for example zero value entered and transmitted by Dinertools, the display shows this error message.
INSUFF. WEIGHT	The selected formula foresees a single unloading of a fixed quantity: the weight on the scale is not enough to execute the dosage. See section 13.1.3.
CHECK PRODUCTION	The production program has been enabled (<<EN.PROD>> step, TECH.MAN.REF), but user did not yet input the number of formula through function 328 , combinable with the desired key. (see section 13.7).
WAIT FOR START	The instrument is ready to start the dosage (see section 13.2).
WAIT STABLE WEIGHT	The instrument is waiting for the stability of the weight at the start of the dosage, for the max. time set in the SETUP (<<WT.STAB>> step, TECH.MAN.REF).
DATA READ ACTIV.	The instrument is reading dosage data.
INSTABILITY ERR	The instrument, at the start of the dosage, has detected the weight as unstable for a time longer than the value set in the SETUP (<<WT.STAB>> step, TECH.MAN.REF). Increase the time or check the stability of the scale. Give a START impulse to exit the error status.
OUT OF ZERO	The weight on the scale, in waiting dosage start condition, exceeds the zero tolerance weight (<<0. TOL>> step, TECH.MAN.REF). Increase the tolerance or remove the exceeding weight before starting the dosage.
ERR. OUT OF ZERO	While the instrument waits for the weight stability at the start of dosage, if the weight on the scale exceeds the zero tolerance weight (<<0. TOL>> step, TECH.MAN.REF) the display shows this error message. Increase the tolerance or remove the exceeding weight. Give a START impulse to exit the error status.
BELOW MIN. TARE	The weight on the scale, in waiting dosage start condition, is less than the min. tare set in the formula. Decrease the value in the formula or put the correct tare on the plate of the scale before starting the dosage.
BEYOND MAX TARE	The weight on the scale, in waiting dosage start condition, is less than the max. tare set in the formula. Increase the value in the formula or put the correct tare on the plate of the scale before starting the dosage.
ERR. OVER MAX TARE	While the instrument waits for the weight stability at the start of dosage, if the weight on the scale exceeds the max. tare value set in the formula the display shows this error message. Increase the tolerance or remove the exceeding weight. Give a START impulse to exit the error status.
FASAUT, SLOAUT, FLIOUT, FASMAN, MAN OK, MANOFF	Status of the dosage, depending on the activity type (see section 13.1).

UNLOAD ALL, FAST, SLOW, UNL OK, STABLE, PAUSE, TIMER, REM. xx, REMOTE SYNC.	
WEIGH OK	The dosage is finished with a weight within the tolerance set in the activity.
TOL. ERR	The dosage is finished with a weight out of the tolerance set in the activity. Correct the weight within tolerance and give a START impulse. See section 13.4.
ERR. OUT OF TIME	The dosage has not finished within the foreseen time in the SETUP (<<T.M.BTC>> step, TECH.MAN.REF). Increase the time or make sure that there is enough material to execute the dosage and give a START impulse.
PCMODE ERROR	The remote dosage has been enabled, but PC.Mode is not set at 485 mode in the Setup → Serial → Com pc step (see the section 13.8).
REM. DISCONNECT	It indicates that the remote communication disconnects; one should check the cable connections and parameter configuration for the serial port.
REM. STATE. ERR	It indicates that the remote instrument is in the error status at the beginning of the remote dosage; one should correct the error.
REM. STARTING	The remote instrument is ready to execute the dosage.
REM. FORMULA. ERR	The selected remote formula index is invalid or inexistent; one should retry to insert a valid formula index in the remote dosage activity.
REMOTE ERROR	The remote instrument is in the PAUSE status.
REM. TARGET. ERR	If the remote instrument enables multicomponent dosage, but EXE.For is not set at "tot.WGt" mode in the F.ModE → doSAGE → doS.PAr step, when the remote dosage starts, the message appears (see the section 13.8).

4.2.6 MESSAGES OF THE INSTRUMENT

While using the indicator, it is possible to incur into the following errors:

INSIDE THE SET-UP OR MENU

MESSAGE	DESCRIPTION
Err.Mot.	The weight is unstable therefore it may not be acquired.
C.Er. – 38 C.Er. – 39	When carrying out the multirange or multidivisional calibration, the ranges have not been entered in an increasing manner (RANGE 1 < RANGE 2 < RANGE 3).
C.Er. – 36	During the calibration some internal negative points have been calculated: <ul style="list-style-type: none"> - the calibration point is less than the zero point. - the signal is negative (check the connections)
C.Er. – 37	During the calibration some internal points less than the minimum value have been calculated: <ul style="list-style-type: none"> - the calibration point is equal to the zero point. - A capacity too high in relation to the division has been set.

AT START-UP

MESSAGE	DESCRIPTION
Err – 37 alternated with no.CAL	The converter points are less than the instrument's internal divisions; one must execute a TECHNICAL DEFAULT (dFLt.t parameter of the SET-UP environment) and carefully carry out the calibration.
Err – 39	Invalid calibration range number (there is the value 0 or values greater than 3); one must execute a TECHNICAL DEFAULT (dFLt.t parameter of the SET-UP environment), if not already executed previously, and carefully carry out the calibration.
Err – 40	The value 0 is in the "range 1" parameter of the calibration; one must execute a TECHNICAL DEFAULT (dFLt.t parameter of the SET-UP environment) and carefully carry out the calibration.
Err – 41	The value 0 is in the "diV 1" parameter of the calibration; one must execute a TECHNICAL DEFAULT (dFLt.t parameter of the SET-UP environment) and carefully carry out the calibration.
hW-Err	HARDWARE ERROR: software not compatible with the installed hardware; the hardware expansion component is missing which allows the software to function.
EXECUTION AUTOZERO	"autozero at start-up" function is active (see section 3.2)

NOTE: if the Er – XX error appears after the indicator start-up; press the TARE key to enter in the SET-UP environment.

DURING THE WEIGHING PHASE, ON ALL OF THE DISPLAYS

MESSAGE	DESCRIPTION
WEIGHT NOT VALID OR UNSTABLE	It is shown in the LCD display when one tries to print or totalise with 0, negative, or unstable weight.
WEIGHT NOT PASSED BY 0 OR UNSTABLE	It is shown in the LCD display when one tries to print or totalise, without having had the weight pass by the net zero or instability.

DURING THE WEIGHING PHASE, IN THE WEIGHT SECTION (CPWE/CPWETF) OR IN THE WEIGHT DISPLAY (on the LED display in 3590E)

MESSAGE	DESCRIPTION
.....	Under weigh -100d (with approved instrument) or over the Maximum Capacity + 9d .
ZERO	Execution of scale zero (see section 6).
TARE	Tare execution (see section 7).
CLEAR	Tare cancellation (see section 7)
prn-on	Turning on printer for maintenance (see section 3.3).
GROSS	Visualisation of the gross weight.
NET	Visualisation of the net weight.
LOCK	Tare lock or enabled keyboard function.
UNLOCK	Tare lock or disabled keyboard function.

5. SCALE SELECTION

If various scales are connected, in order to select these, press the **2ndF** key and then a numeric key from 0 to 4:

- 2ndF and 1** >> Selection of scale number 1.
- 2ndF and 2** >> Selection of scale number 2.
- 2ndF and 3** >> Selection of scale number 3.
- 2ndF and 4** >> Selection of scale number 4.

For example with **2ndF** and the **1** key on the display, the message "SCALE 1" will appear for a few instants and then the value of the Weight on the selected scale.

In case of various connected scales, the selected scale is shown on the display of the instrument:

CPWE/CPWETF

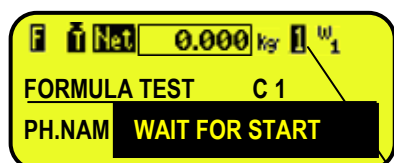

Selected scale:

1 = scale 1; 2 = scale 2; 3 = scale 3; 4 = scale 4

3590E



Selected scale:

1 = scale 1; 2 = scale 2; 3 = scale 3; 4 = scale 4

6. SCALE ZERO FUNCTION

- With various connected scales, select the scale using the numerical keyboard, using the **2ndF** and the **1, 2, 3** and **4** keys.

Keep the **ZERO** key pressed; the message "Zero" appears on the display after which:

- If the weight on the scale is included in the percentage configured in the << **0.PERC** >> (**RIF.MAN.T.**) step, it is zeroed;
- If the weight is not within this range, it will not be cleared and an error sound is emitted.

In the end the indicator automatically returns to the display of the weight present on the scale.

NOTE:

If the cyclical automatic zero has been set at the start-up (in the **SEtUP** >> **ConFig** >> **ParaM** >> **Auto 0** step of the setup, **TECH.MAN.REF.**), by pressing the combination of the **2ndF** and **ZERO** keys, a zero cycle is executed in all the current scales.

7. TARE FUNCTIONS

7.1 SEMIAUTOMATIC TARE

To tare any weight which is on the scale one should:

- press the **TARE** key.

The display shows "**tArE**" for an instant and then 0 (net weight); furthermore also the relative indicators are enabled. The display shows therefore the gross weight value and the stored tare value.

In any case, a new operation automatically cancels and substitutes the previous one.

NOTE: The semiautomatic tare is acquired only if the weight is of AT LEAST ONE DIVISION AND IS STABLE (⚡ instability led indicator is off) and VALID (In other words the UNDERLOAD and OVERLOAD conditions must not be created).

7.2 PRESET TARE

To enter the tare value, one should:

- with the keyboard, type the value (including the decimal point) and press **TARE**.

The indicator automatically subtracts the entered value from the displayed weight, (the relative indicators are enabled), as long as it is not greater than the instrument's maximum capacity.

The display shows therefore the gross weight value and the stored tare value, identified with "PT" (Preset Tare).

The operation can be made either with a loaded or unloaded platform.

In any case, when a new Tare value is entered, the preceding one is cancelled and substituted.

NOTE: In the printout, the manual tare is identified with "PT" (Preset Tare).

7.3 CALCULATED MANUAL TARE

With the "CALCULATOR" function one can add or subtract from the current tare the result of an operation between two values entered with the keyboard.

For the functioning specifics see the 15.3 CALCULATOR section.

7.4 TARE CANCELLATION

To cancel the stored tare:

- With an **unloaded** platform, press the **TARE** key.
- With loaded platform press in sequence the numeric 0 key and **TARE**.
- Press the **C** key.

7.5 LOCKED/UNLOCKED TARE

Normally, when a tare value has been entered (automatically, manually or from storage) by unloading the scale plate, the display shows the tare value with a negative sign (LOCKED TARE). One can also choose that the tare value is cancelled automatically, each time that the scale is unloaded (UNLOCKED TARE).

CONDITIONS FOR AUTOMATIC UNLOCKING:

- In case of **SEMIAUTOMATIC TARE**, the net weight before unloading the scale may also be 0.
- In case of **MANUAL OR CALCULATED TARE**, the net weight before unloading the scale must be of at least 2 stable divisions.

If the **F5** key is pressed at length, it is possible to quickly lock/unlock the tare:

DISPLAY	MEANING
LoCK	LOCKED TARE
Unlock	UNLOCKED TARE

It is possible to carry out this setting or disable completely the tare operations through the << t.Lock >>. LOCKED/UNLOCKED TARE" parameter of the SET-UP environment.

7.6 LIMITATION OF THE TARE FUNCTIONS

For specific requirements, it is possible to limit the tare functions **with approved instrument**.

By setting "YES" in the **SEtuP >> d.SALE** step.

- the SEMIAUTOMATIC TARE can not be modified with a manual or calculated tare.
- the manual or calculated tare must be entered or modified only with UNLOADED scale.

With approved instrument, << **d.SALE** >> step is not displayed. Read only.

7.7 AUTOMATIC ACQUISITION OF THE TARE AT CYCLE BEGINNING

It is possible to configure the instrument so that one can tare the entire weight on the scale during each dosage start phase or to zero it. See section 13.3.2.

7.8 RESTORING TARE AND ZERO AT THE START-UP

By setting "EnAbLE" in the F. ModE→rESTAr step (**TECH.MAN.REF.**) one enables the restoring of the active tares before turning off the instrument, and, if the actual gross weight and the last gross weight stored before the instrument is turned off are higher than zero, the last stored ZERO value is set, otherwise the instrument carries out the auto-zero function.

NOTE: The tares are restored as predetermined tares.

8. MULTIRANGE FUNCTION

The **multi range functioning** allows to subdivide the scale capacity in two or three ranges, each which is up to 3000 divisions, improving in this way the first range division in the dual range and the first two ranges in the triple range.

For example it is possible to approve the weighing system with:

- A single range: 6 kg capacity and 2 g division (3000 div.).
- Dual range: 6 / 3 kg capacity and 2 / 1 g division (3000 + 3000 div.).
- Triple range: 15 / 6 / 3 kg capacity and 5 / 2 / 1 g division (3000 + 3000 + 3000 div.).

NOTE: For the approval of the weighing system in dual and triple ranges the cell must have better technical features in comparison to the cell used for the approval in a single range.

This functioning is indicated by the enabling of the symbol which identifies the range in which one is working: **W1** first range, **W2** second range, **W3** third range (if configured); by passing to the **W2** range, the second range division is enabled; by passing to the **W3** range, the third range division is enabled, at this point the **W1** first scale division is restored **only by passing the gross zero of the scale**.

The **multidivisional functioning** is similar to multirange, but with the difference that a range division is enabled as soon as one enters in its range interval (in other words **without passing by the scale zero**).

NOTE: The selection of the range number with multirange and multidivisional functioning is made during the indicator calibration (**TECH.MAN.REF.**).

9. DISPLAY OF METRIC DATA (inFO)

The indicator is fitted with a function named "INFO", thanks to which it is possible to view the configuration metric data:

- First range capacity, first range division.
- Second range capacity, second range division.
- Third range capacity, third range division.
- Minimum weigh ("e")

NOTES:

- The minimum weigh corresponds to 20 net weight divisions.
- The data of the second and third range appear only if actually configured.

To display the metric data:

- Press in sequence the **2ndF** and **C** key
- "METROLOGIC INFORMATION" is displayed
- The display will show the number of the scale, the type of displayed data and its value.
- Press the **F6** key to quickly scroll the data:
- Press the **F7** key to scroll the previous data backwards.
- Press the **C** key to return to weighing.

10. ENTERING ALPHANUMERIC TEXT

The indicator offers the possibility of using 15 CONFIGURABLE INPUT TEXTS (for example LOT, OPERATOR, SHIFT, etc.) in the **F.ModE** → **tXt** step (**TECH.MAN.REF.**), each contains the following steps:

- **DESCRIPTION** the heading of the input text, up to 16 characters.
- **TEXT** the contents of the input text, up to 32 content characters.
- **THRESHOLD** the length limit of the contents of the input text, from 1 to 32.
- **MANDATORY INPUT** forces to insert contents of the input text.
If the function is enabled, in the weighing phase, by pressing **F4** key to modify the contents of the programmed input texts, only when the contents are not null;
exit from alphanumeric input by pressing **C** key.
- **ONLY VOID INPUT** only access to the input text in which the contents are null.
If the function is enabled, in the weighing phase, by pressing **F4** key only to modify the programmed input texts in which the content are null.

When entered in the TECHNICAL SET-UP (see << **tXt** >>, **TECH.MAN.REF.**), these may be printed later on, if programmed in the printouts; or these may be used as a reminder.

In the weighing phase:

- 1) Press **F4** for an instant and then one can enter the contents of the programmed INPUT TEXTS:
- 2) The display shows "in. XX" on the first line, in which XX is the index of the input text (from 0 to 14) THE HEADING on the second line of the input text (or "Empty..." if empty).
- 3) Use the arrow **▲ ▼** keys to select the text to be filled in and press **ENTER**: now one can enter the alphanumeric text in the second line of the display(see section 4.1.2 ENTERING ALPHANUMERIC TEXT).
NOTE: The length of the enter characters depend on the value set in the "THRESHOLD" step.
- 4) Press **ENTER** to store and pass on to the following stored TEXT; by confirming the last entered text one returns automatically to the weigh functioning;
- 5) it is possible to exit also with the **C** key while in the text selection modification phase.

NOTE:

- a. The entered texts remain in storage until these are substituted or cancelled.
- b. If no text has been configured, the pressing of the **F4** key has no effect.

QUICK MODIFICATION OF AN INPUT TEXT

- By linking the number of a specific input text to the function **113** (preamble function in the << **F.KEYS** >> step, **TECH.MAN.REF.**), it is possible to access directly to the modification of it with a direct key, for example F1 key to quickly access the text 0, and F2 key to quickly access the text 1.
- Through function **121** to **130** combinable with the desired key (<< **F.KEYS** >> step, **TECH.MAN.REF.**), it's possible to quickly modify the contents in the input text 0 to 9.
For example, if the F1 key is associated with function 121, by inserting a string of characters from the external keyboard, and then pressing the F1 key, the string of the characters will be automatically stored in the input text 0 and replace original characters.

QUICK CANCELLATION OF THE CONTENTS OF AN INPUT TEXT OR ALL THE INPUT TEXTS

Through function **131** combinable with the desired key (<< **F.KEYS** >> step, **TECH.MAN.REF.**), it's possible quickly to cancel the contents of the input text.

The function **131** is enabled, one is asked to insert the input text number to cancel; if the number is inserted on 99, it will cancel the contents of all the input texts.

NOTE: Only the contents of the input text are cancelled.

11. DATABASES

11.1 ACTIVITY DATABASE

The indicator has a database in which it is possible to store up to 200 activities (see section 13.1), each having one description of 20 characters; each activity is linked to a storage number, from 0 to 199.

F1 ▶	Activities	F1 ▶	New
		F2 ▶	Edit
		F3 ▶	Delete
		F4 ▶	Search
		F5 ▶	Print
		C ▶	Clear
		./HELP ▶	Help

11.1.1 ENTRY

- 1) Press the **F2** key to enter in the database.
 - 2) Select the eventual desired position:
 - By using the arrow keys ▲ ▼
 - with the keyboard by typing the storage number
 - 3) Press **F1** to enter the activity in the desired position, or in the first free position, if an already occupied position has been selected.
 - 4) Enter the activity description (up to 16 characters) and press **ENTER** to confirm. This parameter allows an easier search of the activity when filling in the formula
 - 5) Select the activity type by using the arrow keys ▲ ▼ and press **ENTER** to confirm:
 - **AUTOMATIC DOSAGE**
 - **MANUAL DOSAGE**
 - **UNLOAD**
 - **TIMER**
 - **PAUSE**
 - **MANUAL WEIGHT**
 - **REMOTE DOSAGE**
 - **SYNCHRONIZATION**
- For details about the functioning mode see section 13.1.

- 6) Each activity must have characteristic parameters, which are shown below:

- **AUTOMATIC DOSAGE**

The characteristic parameters of this activity are, in this order:

SCALE : Select the scale on which the activity will be executed (only when there is more than one scale).

FLY WEIGHT: Enter the **flight material weight**, in other words, the quantity of material which falls, by inertia, when the dosage is stopped. The fine dosage will be stopped by reaching the Target-FLY WEIGHT.

As an alternative it is also possible to set the quantity of **material or weight that is removed** from the scale after the dosage is stopped (for example a part of the filling system that normally goes inside the dosed liquid at end of dosage and is removed after the dosage end), by setting the negative sign for the entered value: select the sign with the arrow keys ◀ ▶ and select the negative sign with the arrow keys ▲ ▼. The fine dosage will be stopped by reaching the Target+FLY WEIGHT.

SLOW WEIGHT: Enter the slow material weight, in other words, the weight of the material which must be dosed in a fine mode (at minimum speed). The fast dosage will be stopped by reaching the Target-SLOW WEIGHT

- TOL. WEIGHT:** Enter the weight (if "WEIGHT" is enabled in the <<tSt.toL>> step, **TECH.MAN.REF**) or the percentage corresponding to target (if "PERC" is enabled in the <<tSt.toL>> step, **TECH.MAN.REF**) which identifies the weight tolerance: if the tolerance test is enabled, the material will be considered valid if it is within the interval:
 $(ACTIVITY\ TARGET - TOLERANCE) \leq WEIGHT \leq (ACTIVITY\ TARGET + TOLERANCE)$
 If the weight is out of the range, an error will be signalled.
- OUTPUT:** Insert the "activity output" number:

For example:

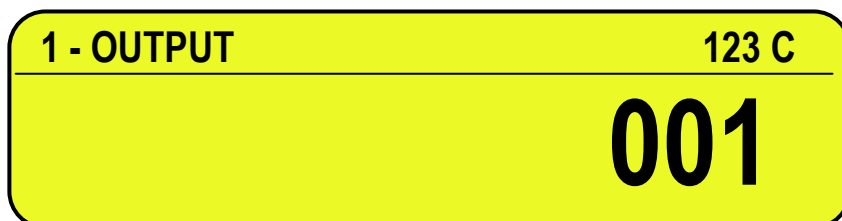

If one enters the "activity output" number 1 during the activity insertion, then output OUT5 will be used (enabled).

ACTIVITY OUTPUT number	RELATED RELAY OUTPUT (see electrical scheme)
1	OUT 5
2	OUT 6
3	OUT 7
4	OUT 8
5	OUT 9
6	OUT 10
7	OUT 11
8	OUT 12
9	OUT 13
10	OUT 14
11	OUT 15
12	OUT 16

- MANUAL DOSAGE

The characteristic parameters of this activity are, in this order:

- SCALE:** Select the scale on which the activity will be executed (only with more than one scale).
- SLOW WEIGHT:** Enter the slow material weight, in other words, the weight of the material which must be dosed in a fine mode (at minimum speed). A message or the traffic light will inform the operator to proceed with the dosage in fine mode when reaching the Target-SLOW WEIGHT.
- TOL. WEIGHT:** Enter the weight (if "WEIGHT" is enabled in the <<tSt.toL>> step, **TECH.MAN.REF**) or the percentage corresponding to target (if "PERC" is enabled in the <<tSt.toL>> step, **TECH.MAN.REF**) which identifies the weight tolerance: if the tolerance test is enabled, the lost material will be considered valid if it is within the interval:
 $(ACTIVITY\ TARGET - TOLERANCE) \leq WEIGHT \leq (ACTIVITY\ TARGET + TOLERANCE)$
 If the weight is out of range, an error will be signalled.

OUTPUT: Insert the “activity output” number:

ACTIVITY OUTPUT	RELATED RELAY OUTPUT (see electrical scheme)
1	OUT 5
2	OUT 6
3	OUT 7
4	OUT 8
5	OUT 9
...	...

- UNLOADING ACTIVITY

The characteristic parameters of this activity are, in this order

SCALE: Select the scale on which the activity will be executed (only with more than one scale).

FLY WEIGHT: Enter the flight material weight, in other words, the quantity of material which falls, by inertia, at the end of the dosage. The fine dosage will be stopped by reaching the Target-FLY WEIGHT.

SLOW WEIGHT: Enter the slow material weight, in other words, the weight of the material which must be unloaded in a fine mode (at minimum speed).

TOL WEIGHT: If the unloading will be total (TARGET=0 in the formula), the tolerance check is not possible (no Target weight to check), therefore enter the value 0 as tolerance weight.
If the unloading is partial, enter the weight (if “WEIGHT” is enabled in the <<tSt.toL>> step, **TECH.MAN.REF**) or the percentage corresponding to target (if “PERC” is enabled in the <<tSt.toL>> step, **TECH.MAN.REF**) which identifies the weight tolerance: if the tolerance test is enabled, the material will be considered valid if it is within the interval:
 $(ACTIVITY\ TARGET - TOLERANCE) \leq WEIGHT \leq (ACTIVITY\ TARGET + TOLERANCE)$
If the weight is out of range, an error will be signalled.

OUTPUT: Select the output of the activity which corresponds to the output on the expansion board.(See table in AUTOMATIC DOSAGE).

At this point one should select in which way the unloading must start (with the arrow keys ▲ ▼ switch the desired mode):

- **DIRECT UNLOAD:** The instrument will automatically pass to the unloading activity at the end of the activity previously executed.
- **WAIT FOR CONFIRMATION:** The instrument will wait for the operator’s consensus in order to start the unloading activity.

- TIMER ACTIVITY

The characteristic parameters of this activity are, in this order:

SCALE: Select the scale on which the activity will be executed (only with more than one scale).

OUTPUT: Select the output of the activity which corresponds to the output on the expansion board.(See table in AUTOMATIC DOSAGE)

At this point one should select in which way the timer must start (with the arrow keys ▲ ▼ switch the desired mode):

- **NOT STOPPABLE:** The timer **can not** be stopped before its configured end.
- **STOPPABLE :** The timer **can** be manually stopped before its configured end; for example, if a time period equal to 10 sec. has been set, it is possible to terminate the timer activity even after 2 sec. by pressing the ENTER key of the instrument.
The instrument, in this way, will interrupt the activity under way and will pass to the next one.

- PAUSE ACTIVITY

The characteristic parameters of this activity are, in this order:

SCALE: Select the scale on which the activity will be executed (only with more than one scale).

OUTPUT. Select the output of the activity which corresponds to the output on the expansion board.(See table in AUTOMATIC DOSAGE)

- **MANUAL WEIGHT**

The characteristic parameters of this activity are, in this order:

SCALE: Select the scale on which the activity will be executed (only with more than one scale).

OUTPUT. Select the output of the activity which corresponds to the output on the expansion board.(See table in AUTOMATIC DOSAGE)

- **REMOTE DOSAGE**

The characteristic parameters of this activity are, in this order:

SCALE 485 address of the remote instrument.

PARAMETER Selection of SEQUENTIAL/PARALLEL execution mode (see section 13.1.7).

REMOTE UNIT Selection of unit of measure of the remote instrument.

REMOTE DECIMAL Selection of the number of decimals of the remote instrument.

REMOTE FORMULA INDEX Selection of the remote formula index to be dosed.

- **SYNCHRONIZATION**

The characteristic parameters of this activity are, in this order:

SCALE 485 address of the remote instrument.

11.1.2 MODIFICATION OF AN ACTIVITY IN THE DATABASE

- 1) Press the **F2** key to enter in the activities database.
- 2) Select the eventual desired position using the arrow keys ▲ ▼ (or with the keyboard type the position number).
- 3) Press **F2** to modify the activity in the desired position
- 4) Modify the suggested parameters in order to pass to the following parameter; confirm with ENTER.
By pressing C one exits the modification step without saving the operations made.

11.1.3 CANCELLATION OF AN ACTIVITY IN THE DATABASE

- 1) Press the **F2** key to enter in the activity database.
- 2) Select the eventual desired position using the arrow keys ▲ ▼ (or with the keyboard type the position number).
- 3) Press **F3** to cancel the activity in the desired position
- 4) The display will show "**SURE?**"
Press ENTER to eliminate the activity as well as all the formulas which contain it, otherwise press C to exit without saving modifications.
NOTE: the activity will be deleted also from all the formulas containing it.

11.1.4 PRINT OF ACTIVITIES IN THE DATABASE

- 1) Press the **F2** key to enter in the activity database.
- 2) Once inside the activities' database press the **F5** key. The display will show "**PRINT ?**": confirm with **ENTER** key for printing the entire database with all the relative data for each activity.

11.1.5 ALPHABETICAL RESEARCH

- 1) Press the **F2** to access the database.
- 2) Press the **F4** key: enter the desired characters to search in the description of all the activities.
- 3) Select the desired storage in the list of the results by using the arrow keys ▲ ▼ and press **ENTER**.
- 4) Carry out one of the operations described in the previous sections.

11.1.6 HELP

By pressing the **./HELP** key, it's possible to see the keys list used in the menu.

The key list is automatically scrolled. If you want to see the keys list in manual mode, use the arrow key (F6 ▼ e F7 ▲).

11.2 FORMULA DATABASE

The indicator has a database in which it is possible to store up to 500 formulas having one description of 20 characters; each formula is linked to a storage number, from 0 to 499. It is possible to associate up to 20 activities to every formula.

F1 ▶	FORMULAS	F1 ▶	New
		F2 ▶	Edit
		F3 ▶	Delete
		F4 ▶	Search
		F5 ▶	Print
		Fn ▶	Select
		2ndF ▶	Deselect
		C ▶	Clear
		./HELP ▶	Help

11.2.1 ENTERING A FORMULA IN THE DATABASE

- 1) Press the **F1** key to enter in the formulas database.
- 2) Select the eventual desired position using the arrow keys **▲ ▼** (or with the keyboard type the position number).
- 3) Press **F1** to insert the formula in the desired position, or with the first free position, if an already occupied position has been selected.
- 4) Enter the formula description (up to 16 characters).
- 5) Enter the number of phases(= activities) which make up the formula; confirm with **ENTER**
- 6) Scroll the activities entered previously using the arrow keys **▲ ▼**, and press **ENTER** to select the desired one.
Depending on the activity, the instrument requests the entry of the **TARGET** (for activities like **MANUAL**, **AUTOMATIC**, **UNLOADING**, **MANUAL WEIGHT**, **REMOTE DOSAGE**, expressed in the unit of measure of the scale on which it will be executed) or of the **TIME** (**TIMER**, expressed in seconds).

NOTES:

- the **PAUSE** activity does not require any parameters.
- the maximum configurable time in the timer activity is 9999,9 seconds.

!! IMPORTANT !!

- In the manual or automatic activities, the sum of the targets of the various formulas must be less than the maximum dosable weight, set in **SETUP**.
 - In order to obtain a **complete unloading** activity enter an activity target equal to 0, while by entering a target different than zero, the **unloading** will be a **split total**.
 - By entering a formula in which the first activity is an unloading one having a target different than 0, one obtains a **partial unloading**.
 - See section 13.1 for further details about the activity functioning mode.
- 7) Once an activity has been selected, the first activity in the database is suggested again.
Repeat the selection procedure (point 6) until all the activities set in point 5) have been programmed.
 - 8) Once the programming of the activities is done, the instrument requests for the entry of the minimum and maximum tare values:
 - a) **MIN TARE**, in which one is asked to enter the **MINIMUM** tare value which must be on the scale before giving the **START** impulse.
 - b) **MAX. TARE**, in which one is asked to enter the **MAXIMUM** tare value which must be on the scale before giving the **START** impulse.

See section 13.3.1 for further details.

11.2.2 SELECTION OF A FORMULA IN THE DATABASE

A formula can be selected in three different ways depending on the **F.ModE** >> **bAtCh** >> **FOR.SEL** parameter configurable in the set-up, **TECH.MAN.REF**.

SELECTION THROUGH THE KEYBOARD

In order to select a formula stored in the database, follow one of the procedures below:

- 1) Press the **F1** key to enter in the formulas database.
 - With the arrow keys ▲ ▼ scroll the formula database until you find the desired one.
 - Select the formula using the ENTER key.
- 2) Press in sequence the numeric key corresponding to the index of the formula in the database and the **F1** key.

The selected formula substitutes the previous one; if no formula is active, the "FORMULA MISSING" error message will appear.

NOTES: if the "FIRST FREE COMPONENT" functioning mode has been set, it is possible to select only the formulas which have a manual dosage as first activity, otherwise in WAIT START condition, the display will show the "FIRST ACT. ERR." error message. See section 13.2.2 for further details.

SELECTION THROUGH 4 EXTERNAL INPUTS

To select a formula stored in database one should enable the four inputs in combination among these, recalling a specific memory storage number depending on the combination.

In the following table there are the possible combinations of the inputs and the recalled memory storage number. The active status is described with the value 1, and the non active status with the value 0:

COMBINATIONS WITH 4 INPUTS

FORMULA NUMBER	IN.6	IN.5	IN.4	IN.3
0	0	0	0	1
1	0	0	1	0
2	0	0	1	1
3	0	1	0	0
4	0	1	0	1
5	0	1	1	0
6	0	1	1	1
7	1	0	0	0
8	1	0	0	1
9	1	0	1	0
10	1	0	1	1
11	1	1	0	0
12	1	1	0	1
13	1	1	1	0
14	1	1	1	1

SELECTION OF PREVIOUS/FOLLOWING FORMULA THROUGH 2 EXTERNAL INPUTS

In order to select a formula stored in a database one needs to enable the inputs 3 or 4, that select respectively, the following and previous formula in order of description.

11.2.3 DESELECTION OF A FORMULA IN THE DATABASE

To unselect a selected formula, for an instant press the **F1** key to enter in the formulas database and press **2nd F**. Before unselecting, a confirmation is requested: press **ENTER** to confirm or another key to cancel.

11.2.4 MODIFICATION OF A FORMULA IN THE DATABASE

- 1) Press the **F1** key to enter in the formulas database.
- 2) Select the eventual desired position using the arrow keys ▲ ▼ (or with the keyboard type the position number).
- 3) Press **F2** to modify the formula in the desired position
- 4) Modify the suggested parameters in order to pass to the following parameter; confirm with ENTER.
By pressing C one exits the modification step.

11.2.5 CANCELLATION OF A FORMULA IN THE DATABASE

- 1) Press the **F1** key to enter in the formulas database.
- 2) Select the eventual desired position using the arrow keys ▲ ▼ (or with the keyboard type the position number).
- 3) Press **F3** to cancel the formula in the desired position
- 4) The display will show “**SURE?**”
Press **ENTER** to eliminate the formula, otherwise press **C** to exit without saving modifications.

11.2.6 PRINT OF FORMULAS IN THE DATABASE

- 1) Press the **F1** key to enter in the formulas database.
- 2) Once inside at the formulas database press the **F5** key. The display will show “**PRINT ?**”: confirm with **ENTER** key for printing the entire database with all the relative data for each formula.

11.2.7 ALPHABETICAL RESEARCH

The access to the ALPHABETICAL RESEARCH is possible in the following 2 ways:

- 1) Press **F1** to access the database and press the **F4** key;
or
- 2) through function **323** combinable with the desired key (<< **F.KEYS** >> step, **TECH.MAN.REF.**).

To search a formula:

- 1) Enter the desired characters to be searched in the description of all the formulas.
- 2) Select the desired storage in the list of the result by using the arrow keys ▲ ▼ and press **ENTER**.
- 3) Carry out one of the operations described in the previous sections.

11.2.8 HELP

By pressing the **/HELP** key, it's possible to see the keys list used in the menu.

The key list is automatically shown. If you want to see the keys list, in manual mode, use the arrow key (F6 ▼ e F7 ▲).

12. DATABASE ACCESS PASSWORD

In the **SETUP** (<< **dtb.PWd** >> parameter) one can set a password for access to the databases. A password will be required only when one wants to insert, modify or delete an element of the archive; for a moment the display shows the message **USER-PRESS KEY**; afterwards, it will be no longer possible to make changes to the database.

To edit, delete, or insert data in the archive:

- Press any key **DURING THE VISUALISATION OF THE “USER-PRESS KEY”**: the instrument requests the entry of the password (a number will appear).
- Enter the password and confirm with **ENTER**.

13. FUNCTIONING OF THE MULTICOMPONENT DOSAGE

The programme has been made to manage automatic/manual multi component dosages, in loading and in unloading, with tolerance control, accumulation, and printing of the executed formulas.

The input/output allows for the automatic dosage management, for the selection of the formulas and for other functions (see technical manual).

To start the dosage, one should start the cycle as described in the following sections.

13.1 FUNCTION OF THE ACTIVITIES AND THE FORMULAS

- **A formula** is the sequence of the activities which allow to execute the desired dosage.
- **An activity** is each single part, component or material that makes up the dosage.

The available activities are:

- AUTOMATIC DOSAGE
- MANUAL DOSAGE
- UNLOADING
- TIMER
- PAUSE
- MANUAL WEIGHT
- **REMOTE DOSAGE**
- **SYNCHRONIZATION**

Each activity executes a specific function, shown in the following sections.

It is possible to assign one of the available outputs to each activity (except for the last two activities):

- The instrument's outputs start from 1; enter 0 to create an activity without linked outputs.
- Refer to the technical manual for further details regarding the maximum activity outputs available and the correspondence on the terminal board.

In order to execute a dosage, one must first of all identify which are the single activities that have to be carried out and enter these in the activity database; after this one must enter a formula in the formula database, which must contain, in order, all the activities which must be carried out in order to execute the desired dosage.

EXAMPLE:

FORMULA: **DOSAGE 01**

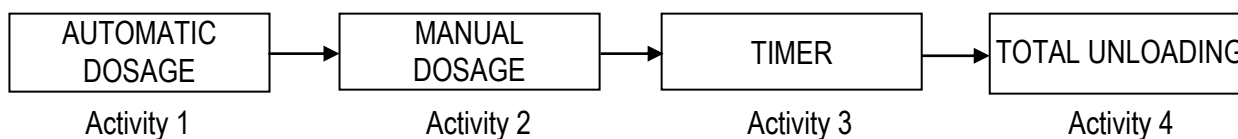

In the suggested example, the instrument will execute an automatic dosage as first activity, and then a manual dosage, then a timer activity, and then, the total unloading of the silo.

The execution order of the activities depends on the order in which these are entered when programming the formula: the first entered activity will be the first executed one, etc.

13.1.1 "AUTOMATIC DOSAGE" TYPE OF ACTIVITY

DESCRIPTION

This activity has the purpose to automatically dose a product:

- This activity automatically starts at the end of the previous one.
- Once the dosage is started the instrument tares the weight on the scale and enables the fast dosage output and the product one: the dosage starts at the maximum speed.
- When the weight reaches the TARGET TO BE DOSED - SLOW DOSAGE WEIGHT - MATERIAL WEIGHT IN FLIGHT threshold, the approximate dosage output disables and the dosage continues in fine mode.
- The dosage ends, with subsequent disabling of the output relative to the linked output, in the moment in which the TARGET minus the MATERIAL WEIGHT IN FLIGHT is reached.
- After this a wait time starts equal to the FLIGHT WAIT TIME (**TECH.MAN.REF**) in which one presumes that material still falls on the scale and the TARGET is reached.
- Once the wait time is finished:
 - 1) If the instrument is enabled, the checks start on the dosage result: if the weight of the dosed material is not within the set tolerance, the " TOL.ERR " error is signalled, and the error output (default = OUT3) is enabled.
Now the operator can remove the exceeding weight or add the missing weight; in this phase it is possible to use the message which appears (**WEIGH OK** if within the tolerance, or **TOL.ERR** if out of tolerance).
By pressing for an instant the external INPUT 1 or the F6 key, one exits the error status: the weight now present will be considered valid and therefore accumulated in the formula production and in the general total.
 - 2) The data of the executed dosage is automatically stored and transmitted through the serial line for the printing or the storage on PC/PLC.
- A wait time starts equal to the DATA READING WAIT TIME (**TECH.MAN.REF**) in order to allow the reading of the activity data; the instrument waits for this time before passing to the following phase.

PHASES OF THE ACTIVITY SHOWN ON THE DISPLAY (see section 4.2):

- **FASAUT** indicates that the material is being dosed at the maximum speed; this abbreviation remains until a weight value is reached in which the SLOW WEIGHT + the FLIGHT WEIGHT is missing from the FINAL WEIGHT.
- At this point the **SLOAUT** abbreviation is displayed indicating the end of the fast dosage and the beginning of the slow dosage.
- When the weight reaches the TARGET (or WEIGHT TO BE DOSED) – THE FLIGHT WEIGHT, the message **FLIAUT** is displayed for the FLIGHT WAIT TIME.

13.1.2 "MANUAL DOSAGE" TYPE OF ACTIVITY

DESCRIPTION

This activity has the purpose of manually dosing a product:

- This activity automatically starts at the end of the previous one.
- It foresees that the dosage is manually executed by the operator; in fact, the operator must manually carry out the dosage and give the dosage end command.
- Once the dosage is started the instrument tares the weight on the scale and enables anyway the fast dosage output and the product one, connectable to a traffic light that informs the operator to dose at maximum speed.
- When the weight reaches the TARGET – SLOW WEIGHT, the fast dosage output is disabled, and the operator must advance with the fine dosage.
- When the weight reaches the TARGET - TOLERANCE, the alarm output is disabled: the operator must continue with the fine dosage until the TARGET is reached.
- The product, OK.TOL and OVER.T outputs can be connected to the traffic light to guide the operator during dosage and inform the operator if the weight is within or out of tolerance. See following section.
- The operator will press for an instant the external INPUT 1 or the F6 key to end the dosage, so that:
 - 1) If the instrument is enabled, the checks on the dosage result start: if the weight of the dosed material is not within the set tolerance, the " TOL.ERR " error is signalled, and the error output (default = OUT3) is enabled.
The operator can remove the exceeding weight or add the missing weight; in this phase it is possible to use the message which appears (**WEIGH OK** if within the tolerance, or **TOL.ERR** if out of tolerance).
By pressing for an instant the external INPUT 1 or the F6 key, one exits the error status: if the mandatory correction is not enabled (see following section) the weight now present will be considered valid and therefore accumulated in the formula production and in the general total.

- 2) The data of the executed dosage is automatically stored and transmitted through the serial line for the printing or the storage on PC/PLC.
- A wait time starts equal to the DATA READING WAIT TIME (**TECH.MAN.REF**) in order to allow the reading of the activity data; the instrument waits for this time before passing to the following phase.

AUTOMATIC END OF THE MANUAL DOSAGE AND MANDATORY WEIGHT CORRECTION

It is possible to decide to have the dosage automatically end, by setting the **WAIT TIME FOR MANUAL DOSAGE END** (**t.d.Man** parameter, **TECH.MAN.REF.**); the instrument, after the weight has reached and exceeded the set target value, waits for the set time, and when it has reached it, it automatically passes to the tolerance check. Furthermore it is possible to decide if the weight must be in tolerance to proceed with the next activity.

By setting "0":

- the activity is ended only by pressing for an instant the external INPUT 1 or the F6 key.
- the system goes into "out of dosage time period error" if the **MAXIMUM TIME FOR THE DOSAGE** has been reached (**t.M.btC** parameter).
- if the tolerance test is enabled (**tSt.toL** parameter, **TECH.MAN.REF.**) and the weight is out of tolerance, this will be anyway accepted by pressing for an instant the external INPUT 1 or the F6 key: the system goes into out of tolerance error and waits for a further confirmation; while if the test is disabled, the instrument passes directly to the following activity.

By setting a value > than 0 but less than "99999.9":

- the activity is automatically ended after the weight has reached and exceeded the set target value and the time is elapsed.
- the system goes into "out of dosage time period error" if the **MAXIMUM TIME FOR THE DOSAGE** has been reached (**t.M.btC** parameter), before reaching the dosage end time.
- if the tolerance test is enabled (**tSt.toL** parameter, **TECH.MAN.REF.**) and the weight is out of tolerance, this will be anyway accepted by pressing for an instant the external INPUT 1 or the F6 key: the system goes into out of tolerance error and waits for a further confirmation; while if the test is disabled, the instrument passes directly to the following activity.

By setting "99999.9":

- the activity is ended only by giving a START impulse or by pressing the F6 key.
- the system does not go into out of dosage time error even if the **MAXIMUM TIME FOR THE DOSAGE** has been set (**t.M.btC** parameter).
- if the tolerance test is enabled (**tSt.toL** parameter, **TECH.MAN.REF.**) the weight is accepted only if it is within tolerance; the external INPUT 1 or the F6 key do not end the activity until the weight becomes within tolerance.

PHASES OF THE ACTIVITY SHOWN ON THE DISPLAY (see section 4.2)

If the outputs are not used, in any case, it is possible to have the indication regarding the dosage advancement on the instrument display:

- **FASMAN** indicates that the material is dosed at the maximum speed; this abbreviation remains until a weight value is reached in which a *SLOW WEIGHT* is missing from the *FINAL WEIGHT*.
- At this point the **MANOFF** abbreviation is displayed indicating the end of the fast dosage, and the beginning of the slow dosage and also that the weight is not within the minimum tolerance.
- When the weight is again within the *TOLERANCE* interval the message **MAN OK** is shown. If at this point the maximum tolerance value is exceeded, the message **MANOFF** will again be displayed.

13.1.2.1 FUNCTIONING WITH CONTROL LIGHT

In order to simplify the work of the operator during the manual dosage activity, it is possible to connect a control light to the instrument relays.

2 outputs must be configured as "OK.TOL" and "OVER.T", in <<OUTPUT>> step (TECH.MAN.REF.).

CONNECTION:

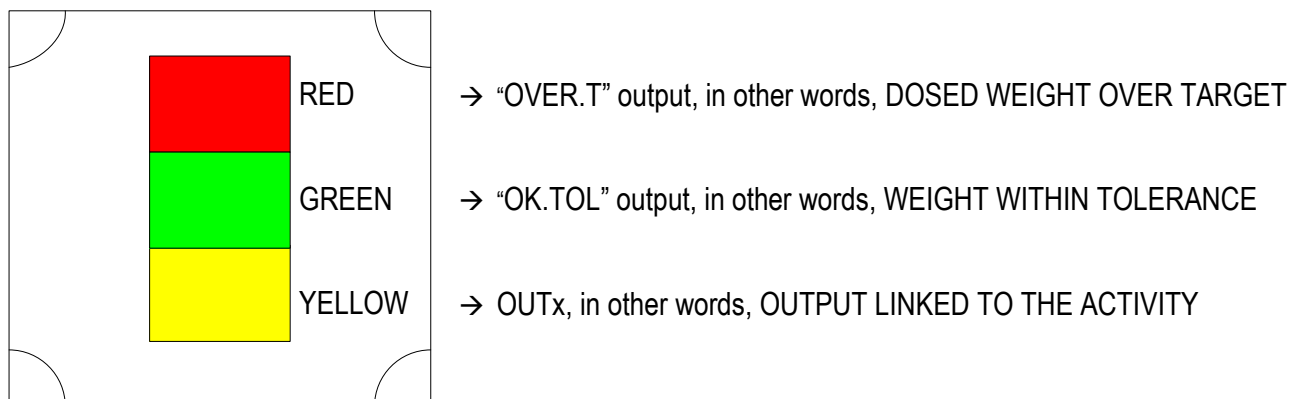

FUNCTIONING:

If <<EXE.FOR>> step is set on "WGT.FOR" or "TOT.WGT" mode (TECH.MAN.REF), the function of light control is below.

- The lights are enabled depending on the weight reached during the manual dosage:

WEIGHT	TARGET-TOL.	TARGET	TARGET+TOL.
RED		ON	ON
GREEN	ON	ON	
YELLOW	ON	ON	

- The operator gives the START impulse; the yellow light is enabled.
The operator starts dosing in an approximate mode, in other words, at maximum speed.
- Once the weight is greater than (TARGET - TOLERANCE) and lower than TARGET, the green is enabled, while the yellow light remains active. The operator can continue the dosage to reach the TARGET weight.
- Once the weight reaches TARGET, the yellow light turns off, only the green light remains active.
- Once the weight is greater than TARGET and lower than (TARGET + TOLERANCE), the red light is enabled, while the green light remains active indicating that the weight is still within tolerance. The operator can continue the dosage until the green light is on.
- Once the weight is greater than (TARGET + TOLERANCE), the green light is disabled, only the red light remains active.

If <<EXE.FOR>> step is set on "1A.FREE" mode (**TECH.MAN.REF**), the function of light control is below. See section 13.2.2 for details on the functioning mode.

- The lights are enabled depending on the weight reached during the manual dosage:

WEIGHT	MIN WEIGHT	MAX WEIGHT	
RED			ON
GREEN		ON	
YELLOW	ON		

- The operator gives the START impulse; the yellow lights is enabled. The operator starts dosing in an approximate mode, in other words, at maximum speed.
- Once the weight is greater than the minimum dosable weight and lower than maximum one, the yellow light turns off, instead the green light is enabled.
- Once the weight is greater than the maximum dosable weight, the green light turns off, instead the red light is enabled.

13.1.3 "UNLOADING" TYPE OF ACTIVITY

It is possible to execute 3 different unloading methods of the silo:

- TOTAL UNLOADING OF THE SILO**

DESCRIPTION

This activity has the purpose of completely unloading the silo:

- It is entered at the end of a loading formula or at the end of a partial or split unloading activity (see following unloading methods), so that the remaining material is unloaded.
- It may also be entered in a single component formula, becoming a formula which allows the total unloading of the silo, and may be enabled also without having to load the silo.
- In order to obtain a total unloading activity, one should enter an unloading activity in the activity database; then, in the formula, one should enter the unloading activity with a target equal to 0 (see section 11.1).
- It is possible to program in the activity database how the unloading should start, once the previous activity has ended: automatically or manually (by pressing the external INPUT 1 or the F6 key).
- Once the dosage is started the instrument zeroes the weight on the scale and enables the approximate dosage output and the product one: the complete unloading always takes place at maximum speed and does not foresee the tolerance check.
- The display, during the unload activity, shows the "**UNLOAD ALL**" message (see section 4.2).
- As soon as the weight reaches the TOTAL UNLOADING END a wait time starts equal to the UNLOADING END WAIT TIME (**TECH.MAN.REF**).
- Once the wait time is finished the activity ends, with subsequent disabling of the fast dosage and product outputs.
- The data of the executed dosage is automatically stored and transmitted through the serial line for the printing or the storage on PC/PLC.
- A wait time starts equal to the DATA READING WAIT TIME (**TECH.MAN.REF**) in order to allow the reading of the activity data; the instrument waits for this time before passing to the following phase.

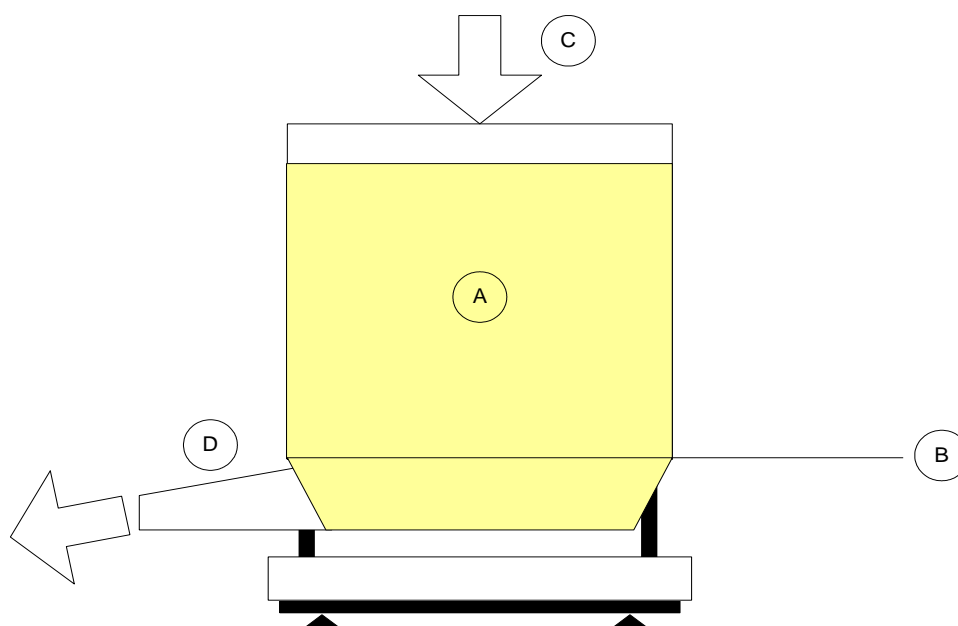
EXAMPLE

- A: material to be unloaded
- B: TOTAL UNLOADING END weight
- C: loading of the silo
- D: unloading of the silo

- **SPLIT TOTAL UNLOADING**

DESCRIPTION

This activity has the purpose of completely unloading the scale after one or more loading dosages, **SPLITTING the dosage in various partial unloads** which have a fixed partial target, programmable in the formula (example: unload 2000kg in 20 dosages of 100kg):

- In order to obtain a split total unloading activity, one should enter an unloading activity in the activity database; then, in the formula, one should enter the unloading activity after one or more loading activities, with a target equal to the partial TARGET, for example 100kg (see section 11.1). By entering an unloading activity as first activity of the formula, one obtains a partial unloading (see following unloading method).
- Each single unloading is managed as a partial unloading activity (see following unloading method for details).
- It is possible to program in the activity how the first unloading should start, once the previous activity has ended: automatically or manually (by pressing the external INPUT 1 or the F6 key). Each following unloading will be manually enabled by pressing the external INPUT 1 or the F6 key: in this way the operator, for example, can change the container with each partial unloading.
- At the end of each single unloading the instrument checks if the weight is sufficient to execute a further unloading: if the weight is lower than the TOTAL UNLOADING END + ACTIVITY TARGET threshold the split unloading activity ends and the instrument automatically passes to the following activity.
- Therefore, in order to obtain a total unloading, one should enter a split unloading in the formula (entering an unloading activity having a target different than 0), followed by a total unloading activity (see previous unloading method for details).
- If the UNLOADING END WAIT TIME is set, only the total unloading will end and the relative outputs be disabled, as soon as the weight reaches the TARGET and this time has passed: each single unloading end is managed as in the partial unloading activity (see following unloading method for details).
- A wait time starts equal to the DATA READING WAIT TIME (**TECH.MAN.REF**) in order to allow the reading of the activity data; the instrument waits for this time before passing to the following phase.

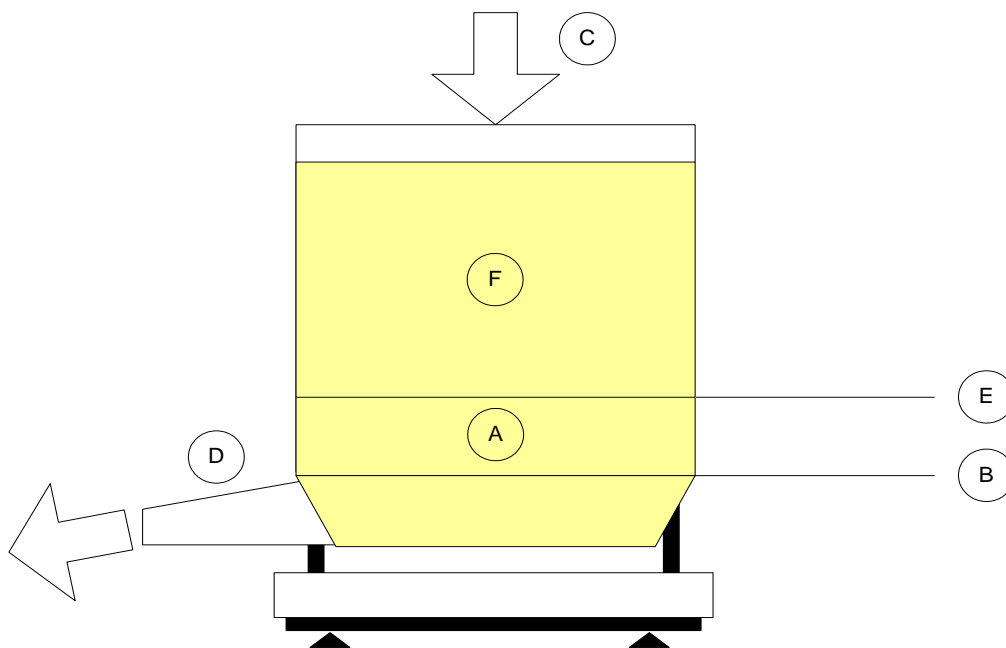
EXAMPLE

- A: safekeeping material, which allows to terminate the last split unloading activity.
- B: TOTAL UNLOADING END weight
- C: loading of the silo
- D: unloading of the silo
- E: split unloading end threshold (in other words **B** + PARTIAL TARGET of the single unloading activity)
- F: total material to be unloaded (TOTAL TARGET)

- **PARTIAL UNLOADING**

DESCRIPTION

This activity has the purpose of **executing a single unloading of a fixed quantity of material**; therefore the instrument gives the possibility to load the silo and then to unload the desired quantity from it:

- To obtain a dosage of this type, one should enter an unloading activity as first activity of the formula, or a single component formula made up of a single unloading activity, with a target greater than 0 (see section 11.1).
By entering an unloading activity with target equal to 0, one obtains a total unloading (see first unloading method), by entering an unloading activity after another activity, one obtains a split unloading (see second unloading method).
- Once the dosage is started, the instrument checks if the weight is sufficient to execute the partial unloading: if the weight is lower than the TOTAL UNLOADING END + ACTIVITY TARGET threshold the "INSUFF.WEIGHT" error message will appear; one exits the error status by pressing for an instant the external INPUT 1 or the F6 key, once the weight is greater than the required one.
- The instrument zeroes the weight on the scale and enables the fast dosage output and the product one: the dosage starts at the maximum speed.
- When the weight reaches the TARGET TO BE DOSED - SLOW DOSAGE WEIGHT - MATERIAL WEIGHT IN FLIGHT threshold, the approximate dosage output disables and the dosage continues in fine mode.
- The dosage ends, with subsequent disabling of the output relative to the linked output, in the moment in which the TARGET minus the MATERIAL WEIGHT IN FLIGHT is reached.
- After this a wait time starts equal to the FLIGHT WAIT TIME (**TECH.MAN.REF**) in which one presumes that material still falls on the scale and the TARGET is reached.

- Once the wait time is finished:
 - 1) If the instrument is enabled, the checks on the dosed weight starts: if the weight of the dosed material is not within the set tolerance, the " TOL.ERR " error is signalled, and the error output (default = OUT3) is enabled. Now the operator can remove the exceeding weight or add the missing weight; in this phase it is possible to use the message which appears (**WEIGH OK** if within the tolerance, or **TOL.ERR** if out of tolerance). By pressing for an instant the external INPUT 1 or the F6 key, one exits the error status: the weight now present will be considered valid and therefore accumulated in the formula production and in the general total.
 - 2) The data of the executed dosage is automatically stored and transmitted through the serial line for the printing or the storage on PC/PLC.
- A wait time starts equal to the DATA READING WAIT TIME (**TECH.MAN.REF**) in order to allow the reading of the activity data; the instrument waits for this time before passing to the following phase.

PHASES OF THE ACTIVITY SHOWN ON THE DISPLAY (see section 4.2):

- **FAST** indicates that the material is being unloaded at the maximum speed; this abbreviation remains until a weight value is reached in which the SLOW WEIGHT + the FLIGHT WEIGHT is missing from the FINAL WEIGHT.
- At this point the **SLOW** abbreviation is displayed indicating the end of the fast unloading and the beginning of the slow unloading.
- When the weight reaches the TARGET (or WEIGHT TO BE UNLOADED) – TOLERANCE WEIGHT, if the FLIGHT WEIGHT is not set or not reached, the message **UNL OK** is displayed.
- When the weight reaches the TARGET (or WEIGHT TO BE UNLOADED) – THE FLIGHT WEIGHT, the message **STABLE** is displayed for the FLIGHT WAIT TIME.

13.1.3.1 NET/GROSS WEIGHT DISPLAY AT THE END OF UNLOADING ACTIVITY

It is possible to decide to have at the end of the unloading activity, the visualization of the remaining weight (gross weight on the scale) or the unloaded weight (negative net weight).

Normally the remaining gross weight is shown on the display, by setting the <<diSP.n.G>> step on nEt (**TECH.MAN.REF.**) only the unloaded weight will be shown.

This can be useful if one wants to know exactly the unloaded material quantity before proceeding with the following activity, especially when the weight is in tolerance, and therefore the unloading would automatically end without possibility to show the unloaded weight.

13.1.4 "PAUSE" TYPE OF ACTIVITY

DESCRIPTION

This activity has the purpose to interrupt the dosage in the case an operation must be executed by the operator or automatically with the use of the enabled relative output:

- This activity automatically starts at the end of the previous one.
- It foresees that it is manually ended by the operator; in fact, the operator must give the dosage end command.
- It does not foresee a target weight to reach: normally the eventual weight added is not stored; it is possible to decide to store the weight added during the pause activity by enabling the **DOSED WEIGHT SUM DURING PAUSE (Add.P** parameter, **TECH.MAN.REF.**), and, in this case, the dosage of the eventual materials necessary for this activity must be manually stopped.
- During the PAUSE activity, it is possible to pause the dosage (through the external INPUT 2 input or the F10 key) disabling all the active outputs.
- Once the dosage is started the instrument tares the weight on the scale and enables the eventual linked output.
- The display, during the pause activity, shows the **PAUSE** message (see section 4.2).
- To end the dosage, the operator will press for an instant the external INPUT 1 / F6 key or the external INPUT 8 (depending on the <<P.INPUT>> step, **TECH.MAN.REF.**), so that:
 - 1) The eventual linked output will be disabled.
 - 2) The data of the eventual executed dosage is automatically stored and transmitted through the serial line for the printing or the storage on PC/PLC.
- A wait time starts equal to the DATA READING WAIT TIME (**TECH.MAN.REF**) in order to allow the reading of the activity data; the instrument waits for this time before passing to the following phase.

13.1.5 "TIMER" TYPE OF ACTIVITY

DESCRIPTION

This activity has the purpose of enabling, for the programmed time, an output, which can be connected to a stirrer, a mixer, a burner, or, generally, to a device which should be enabled for a pre-established time and disable itself automatically:

- This activity automatically starts at the end of the previous one.
- It is possible to set in the activity database the type of timer which one wants to use:
 - **stoppable:** the timer activity may be also terminated at any time manually by pressing for an instant the external INPUT 1 / F6 key or the external INPUT 7 (depending on the <<T.INPUT>> step, **TECH.MAN.REF.**).
 - **not stoppable:** It's not possible to stop the timer before the end that has been set.
- It does not foresee a target weight to be reached: normally the eventual weight added is not stored; it is possible to decide to store the weight added during the timer activity by enabling the **DOSED WEIGHT SUM DURING TIMER (Add.T** parameter, **TECH.MAN.REF.**), and, in this case, the dosage of the eventual material necessary for this activity must be manually stopped.
- During the **TIMER** activity, it is possible to pause the dosage (through the external INPUT 2 input or the F10 key) disabling all the active outputs and freezing the timer at the reached time. To resume the activity, press the external INPUT 1 or the F6 key: the instrument will restart counting from the frozen timer value.
- If the instrument turns off during the timer activity, when the instrument turns back on, it goes into the dosage pause status; by pressing the external INPUT 1 or the F6 key, the timer is reset and the counting restarts from 0.
- Once the dosage is started the instrument tares the weight on the scale and enables the eventual linked output
- The display, during the pause activity, shows the **TIMER** message (see section 4.2).
- The activity automatically ends when the set time has passed:
 - 1) The eventual linked output will be disabled.
 - 2) The data of the eventual executed dosage is automatically stored and transmitted through the serial line for the printing or the storage on PC/PLC.
- A wait time starts equal to the **DATA READING WAIT TIME (TECH.MAN.REF)** in order to allow the reading of the activity data; the instrument waits for this time before passing to the following phase.

13.1.5.1 ALARM OUTPUT AND ACTIVATION MODE OF THE NEXT ACTIVITY

If the timer is stoppable, it is possible to:

1) decide to enable an error if the timer is stopped before its end, by setting the **ALARM MODE** on **STOP (T.ALARM** parameter, **TECH.MAN.REF.**):

- The **ALARM** message is signalled, and the error output (default = OUT3) is enabled when the activity is stopped.
- To resume the activity, press the external INPUT 1 or the F6 key: the timer is reset and the counting restarts from 0.

This can be useful if the timer stopping (through the INPUT 1 or INPUT 7) is caused by an error on the device enabled during the set time: this device supplies a signal on the input when this error occurs.

2) decide to pass to the following activity when the timer is stopped and have instead an error if it is not stopped and the timer ends, by setting the **ALARM MODE** on **TIMEOUT (T.ALARM** parameter, **TECH.MAN.REF.**):

- The **ALARM** message is signalled, and the error output (default = OUT3) is enabled if the activity is not stopped during the set time.
- To resume the activity, press the external INPUT 1 or the F6 key: the timer is reset, the counting restarts from 0 and the instrument waits again for the time stop during the set time to pass to the following activity.

This can be useful if the purpose of the activity is to define a maximum time in which the device must be enabled and give a response to the instrument in order to proceed, or an error if a signal is not given.

13.1.6 "MANUAL WEIGHT" TYPE OF ACTIVITY

This activity is useful when one wants to add to the dosage an amount of material having a known fixed weight, which is set when entering the activity in the database, counting it in the consumptions without having to dose it (for example, a bag of dust of 20kg, a tank of additives of 3kg...).

Therefore it may be set at the dosage end, for example, to remind the operator to add this material to the formula in execution.

- This activity automatically starts at the end of the previous one.
- It foresees that it is manually ended by the operator; in fact, the operator must give the dosage end command.
- Once the dosage is started, the instrument tares the weight on the scale and enables the eventual linked output.
- The display, during the "Manual Weight" activity, shows the **MAN.W.** message (see section 4.2).
- The operator can add the pre-weighed quantity of material to the already dosed weight.
- It is not necessary to add the material on the scale, the activity ends also without dosing the weight, and the weight set in the formula will be always counted in the consumptions, independently from the dosed weight.
- To end the activity the operator will press for an instant the external INPUT 1 or the F6 key, so that:
 - 1) The eventual linked output will be disabled.
 - 2) The data of the executed activity is automatically stored and transmitted through the serial line for the printing or the storage on PC/PLC.
- A wait time starts equal to the DATA READING WAIT TIME (**TECH.MAN.REF**) in order to allow the reading of the activity data; the instrument waits for this time before passing to the following phase.

13.1.7 "REMOTE DOSAGE" TYPE OF ACTIVITY

DESCRIPTION

This activity is designed to control remote devices connected by RS485 to the indicator. Remote dosages can be programmed to "SEQUENTIAL" or "PARALLEL" mode.

SEQUENTIAL mode: the dosage is managed sequentially; the indicator displays the remote dosage and waits until its end. By planning more sequential dosages, the indicator will run them one after another.

PARALLEL mode: it allows to execute a remote dosage (up to 8 at the same time) without waiting its end.
 Note: Unless the remote dosage is the last activity of the recipe, the indicator will allow you to perform the following activities without waiting for its termination. To force the indicator to wait until the end of the parallel remote dosage, use the activity "SYNCHRONIZATION" (see next paragraph).

- This activity automatically starts at the end of the previous one.
- Once the remote dosage is started and the remote instrument tares the weight on the scale connected to it.
- During the "Remote Dosage" activity, if the SEQUENTIAL mode is enabled, the display shows the **REM. XX** message (xx indicates 485 address of the remote instrument) and the weight window shows the weighing value of the remote instrument; if the PARALLEL mode is enabled, the display shows the **REMOTE DOSAGE** message and the weight window shows the progress bar in percentage for the remote dosage (just in case it's the last activity of the recipe, otherwise the indicator will proceed with the following activities).
- All the dosage requirements should be in accordance with the selected formula in the REMOTE FORMULA INDEX (see the section 11.1.1).
- After the remote dosage is terminated, a wait time starts equal to the DATA READING WAIT TIME (**TECH.MAN.REF**) in order to allow the reading of the activity data; the instrument waits for this time before passing to the following phase.

13.1.8 "SYNCHRONIZATION" TYPE OF ACTIVITY

DESCRIPTION

This activity is useful when the PARALLEL mode (see the previous section) is enabled in the remote dosage and the user just wants to execute the following phase after all the remote dosage or a remote dosage is terminated (set 485 address at 255 for all the remote dosage, or a specific 485 address for a remote dosage, see the section 11.1.1) forcing the indicator not to continue with the next activity as long as the dosage is not finished.

NOTE: generally, the activity is used together with remote dosage activity.

- This activity automatically starts and follows the remote dosage activity.
- During the "SYNCHRONIZATION" activity, the display shows the **REMOTE SYNC.** message.
- To end the activity:
 - If the 485 address is set at 255, when all the remote dosages are terminated.
 - If the 485 address is set at a specific address for a remote dosage, when that dosage is terminated.
- A wait time starts equal to the DATA READING WAIT TIME (**TECH.MAN.REF**) in order to allow the reading of the activity data; the instrument waits for this time before passing to the following phase.

13.1.9 FILTERING TIME

To avoid that eventual weight peaks end the dosage activities before the real weight threshold is reached, it is possible to set a minimum time (**FLT.TIM** parameter, **TECH.MAN.REF.**) in which the weight must remain over the disabling threshold (TARGET-FLY WEIGHT or TOTAL UNLOADING END) in order to end the dosage.

If the weight returns under the disabling threshold within this time, the dosage continues as before the weight peak.

13.1.10 MAXIMUM DOSAGE TIME

If the MAXIMUM DOSAGE TIME has been enabled, it is possible to check the dosage execution time.

If, during this time period, the dosage is not yet done, the instrument shows on the display the "ERR. OUT OF TIME" message and the output error is enabled.

The instrument enters in the dosage PAUSE status (see section 13.3.3).

This function, for example, can be used to signal the end of the material in the stockpile silo (in other words, in the silo from which the material to execute the dosage is taken from); in fact, if the material in the silo ends and it is not possible to end the cycle, once the set time has passed, the error is signalled; the operator must manually fill the stockpile silo.

By pressing for an instant the external INPUT 1 or the F6 key, the cycle starts again in the condition in which it was in before the error took place.

13.2 FORMULA EXECUTION MODES

The instrument can execute the formula in 3 ways depending on how the system has been configured (see the <<EXE.For>> step, **TECH.MAN.REF.**):

- FORMULA WEIGHS (WGt.For):
- RECALCULATION OF WEIGHTS IN RESPECT TO FIRST FREE ACTIVITY (1A.FrEE):
- RECALCULATION OF WEIGHTS IN RESPECT TO TOTAL (tot.WGt):

13.2.1 FORMULA WEIGHS

If the "FORMULA WEIGHS" functioning mode has been enabled in the set-up, the dosage is carried out as set in the formula.

In other words the instrument executes all the activities in the formula by dosing the programmed weights, without any recalculation.

13.2.2 RECALCULATION OF WEIGHTS IN RESPECT TO FIRST FREE ACTIVITY

If the "FIRST FREE COMPONENT" functioning mode has been enabled in the set-up it is possible to have two different kinds of activities as first activity: manual dosage or manual weight; on the basis of the dosed or known quantity of material, the instrument recalculates the weights to be dosed of all the following loading activities which make up the formula, proportionally to the target of the basic formula.

The first activity of the formula must be a manual dosage or manual weight; otherwise, the "FIRST ACT. ERR." message will be displayed and it will not be possible to carry out the formula.

The quantity of dosed material for the first component must be within the range proposed by the instrument.

- If first activity of the formula selects a manual dosage:

CPWE/CPWETF

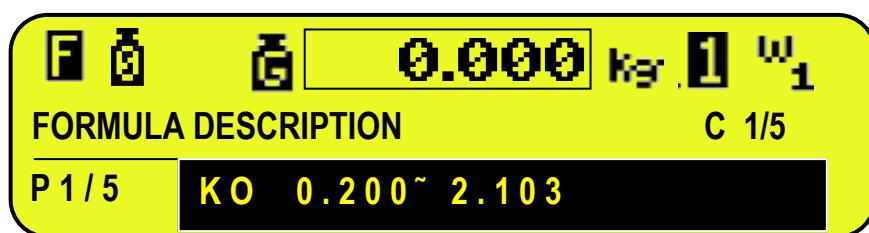

3590E

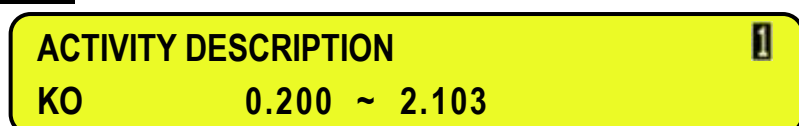

The "OK" message indicates that the weight is within the tolerance range; otherwise "KO" will be displayed. Once the desired material has been dosed, one should press the START button to pass to the next activity.

NOTES:

- The recalculated dosage considers also the gross weight on each scale at the start of the dosage.
- The minimum dosable weight is always equal to 1/5 of target of first manual dosage.

- If first activity of the formula selects a manual weight.

- When the F6 key is pressed or the input 1 is closed and the dosage starts, the display shows:

CPWE/CPWETF

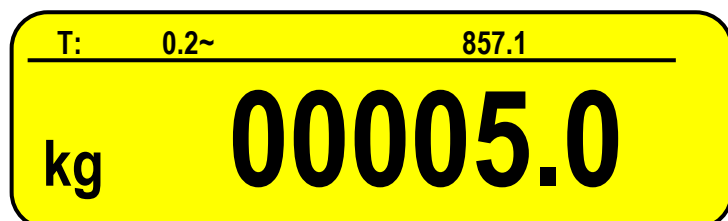

3590E

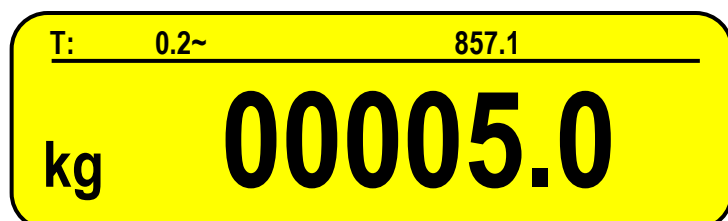

- Enter the known weight for the first activity of the formula and press Fn/ENTER key.
- The instrument will automatically execute the following phases.

NOTE:

- The known weight must be within the range shown on the display.
- The maximum enterable value is 999999999.

EXAMPLE**BASIC FORMULA**

1) MANUAL DOSAGE
or MANUAL WEIGHT 10kg
2) AUTOM. DOSAGE 20kg
3) MANUAL DOSAGE 30kg
4) MANUAL WEIGHT 40kg
5) COMPLETE UNLOADING
TARGET= 100kg

**RECALCULATED FORMULA**

1) MANUAL DOSAGE
or MANUAL WEIGHT 60kg (first free component)
2) AUTOM. DOSAGE 120kg
3) MANUAL DOSAGE 180kg
4) MANUAL WEIGHT 240kg
5) COMPLETE UNLOADING
TARGET= 600kg

13.2.3 RECALCULATION OF WEIGHTS IN RESPECT TO TOTAL

In the "TOTAL WEIGHT" functioning mode one sets the total weight to dose, in the database unit of measure, and, on the basis of this total, the instrument recalculates the weights to be dosed of all the loading activities which make up the formula, proportionally to the target of the basic formula.

The recalculation of the weights has no effect on the partial unloading single component formulas and on the single unloading activities.

In this mode one must enter a basic formula, in which each activity covers a certain percentage in respect to the target.

It is advisable to enter, for each activity, a target equal to the percentage which that activity should have in respect to 100%. After this, one enters the total weight which one wants to dose.

EXAMPLE: 1000kg

The instrument automatically recalculates the weight to be dosed for each activity of the selected formula, on the basis of the percentage which these have in respect to the formula's target.

BASIC FORMULA

Component 1: 20kg
Component 2: 15kg
Component 3: 40kg
Component 4: 25kg

RECALCULATED FORMULA

Component 1: 200kg
Component 2: 150kg
Component 3: 400kg
Component 4: 250kg

All the formula weights are converted into the database's unit of measure and decimals, with all the eventual roundings.

13.2.3.1 TOTAL WEIGHT TO LOAD OVER THE MAXIMUM DOSABLE WEIGHT

If the total weight of the various loading activities exceeds the maximum dosable weight (<<MAX.WGT>> step, **TECH.MAN.REF.**), the instrument calculates the number of consecutive repetitions which it must execute in order to reach the set total weight.

EXAMPLE

By examining the previous example, if the maximum dosable weight would have been equal to 800kg, the instrument would execute 2 consecutive repetitions of the following formula:

Component 1: 100kg
Component 2: 75kg
Component 3: 200kg
Component 4: 125kg

Furthermore:

- After each repetition the instrument corrects the weight to be dosed for each activity of the following cycle, on the basis of the quantity that has been dosed in the previous cycle.
- It is possible to decide to execute the fine dosage for each activity always in each cycle or only in the last cycle, by setting the **SLOW EXECUTION MODE (SLOW.M** parameter, **TECH.MAN.REF.**). This is useful if one wants to dose at maximum speed in every cycle, and manage the slow speed (fine dosage) only in the last cycle.
- With various dosage cycles (see section 13.3.5), the instrument executes the set repetitions with the same quantity of material.

13.2.3.2 ENTERING THE TOTAL WEIGHT

- 1) Press the **F7** key.
- 2) Enter the total weight to be dosed (the display will show the database's unit of measure).
- 3) Confirm with ENTER key.
- 4) Start the dosage (See section 13.3).
- 5) The instrument will automatically execute all the necessary dosage repetitions in order to dose the total quantity of the set material.

NOTES:

- With an approved instrument, one should give a start impulse between one dosage and another.
- If <<PRN.FOR>> step is set on "YES" (**TECH.MAN.REF.**), when the set total weight is changed, one will be asked to print the recalculated formula data.
- In this functioning mode, it's not possible to use the dosage cycle repetition function.

13.3 PROCEDURES OF THE DOSAGE CYCLE

In order to execute a dosage, one should:

- fill in the activity database
- fill in the formula database
- select the formula to be executed
- press the external START button, which must be connected to the IN1 input of the instrument, or the F6 key.

For further details, see section 13.3.1.

By supplying the dosage start to the system, the following takes place

- the verification of the correct tare presence and the weight stability
- the automatic tare of all the connected platforms
- the selection of the scale on which to dose

The instrument executes the first activity of the recipe. See section 13.1 for details on the functions of the activities.

Once the first activity is finished, the instrument:

- selects the scale on which to dose
- executes the automatic tare
- executes the following activity

These operations are repeated for all the activities which compose the recipe.

At the end of the last activity, the instrument activates the end cycle contact and waits to receive the start of the new dosage, or, in case of various repetitions of the dosage cycle, restarts automatically with the following cycle.

To pause a dosage under way, one should:

- press the external PAUSE button, which must be connected to the IN2 input of the instrument, or the F10 key.
- to restart the interrupted dosage, give a START command.

For further details, see section 13.3.3.

To reset a dosage under way, one should:

- press at length the external PAUSE button or press 2 times the F10 key, until the display shows the "rESEt" message.

For further details, see section 13.3.4.

To set the number of times which the instrument must repeat the selected formula, one should:

- press the **F8** key and enter the number of repetitions to be executed.

For further details, see section 13.3.5.

13.3.1 DOSAGE CYCLE START

To start the dosage cycle, press for an instant the external INPUT 1 or the F6 key. In order to start with the dosage, the weight on the scale:

- 1) must be stable or become stable within a waiting time equal to the value set in the <<FLY.TIM>> parameter, **TECH.MAN.REF.**
- 2) must be less than the value set in the <<O.TOL>> parameter, **TECH.MAN.REF.**
- 3) must be greater than **TAR.MIN** and less than **TAR. MAX** (if programmed).
- 4) must be stable within the time set in the <<WT.STAB>> parameter, **TECH.MAN.REF.**

If any one of these condition are not respected an error message is shown on the system status info section of the display, see section 4.2.5.

By pressing for an instant the external INPUT 1 or the F6 key, the cycle starts again.

13.3.2 AUTOMATIC ACQUISITION OF THE TARE OR ZERO AT CYCLE BEGINNING

It is possible to configure the instrument so that one can tare the entire weight on the scale during each dosage start phase or to zero it.

By setting the F.ModE→bAtCh→En.tArE step (**TECH.MAN.REF**) on **diSAbL**:

- if no tare value has been entered, the entire weight on the scale is zeroed;
- while if a semiautomatic or manual tare is entered, the net weight is considered to be the dosage weight start.

By setting the F.ModE→bAtCh→En.tArE step (**TECH.MAN.REF**) on **EnAbLE** the gross weight on the scale is entirely tared; therefore the dosage always starts with the net weight at zero.

13.3.3 PAUSE – MOMENTARY INTERRUPTION OF THE DOSAGE CYCLE

To pause the dosage press for an instant the external PAUSE button or the F10 key. In order to carry out this operation all the instrument's outputs are disabled; The display shows the message PAUSE.

To exit this PAUSE condition give a START command.

If during the dosage the mains voltage goes missing, when it is restored, the instrument will turn on automatically into DOSAGE PAUSE, give a START command to continue with the interrupted dosage.

The dosage will start again in the condition in which the instrument was in when it was turned off.

In the PAUSE condition it is possible to access the <<n.CyCLE>> "DOSAGE CYCLE REPETITIONS" step of the F8 key, in which it is possible to change the number of the cycles.

Furthermore it is possible to turn off the instrument by pressing the C key at length.

13.3.4 DOSAGE CYCLE RESET

To cancel the dosage cycle in execution press the PAUSE button for about 3 seconds or press 2 times the F10 key. The "rESEt" message will be shown on the display.

By carrying out this operation the indicator cancels the dosage and the GROSS weight on the scale plate appears on the display. By cancelling the dosage under way, if the material has been dosed, the production of the single formula and the general total is increased.

To cancel a dosage during a repetition of the dosage cycles, one should carry out a reset (previously described); the LED display (to 3590E) or the LCD display (to CPWE/CPWETF) will show "rESEt" and then "CyCLE"; after this the instrument is in the WAIT START status: by giving a start command the number of executed dosages shown on the display is increased by 1, and the dosage continues with the following cycle.

To cancel a set repetition of cycles, one should execute a reset in order to exit the dosage cycle: the message "CyCLE" will appear for a few instants on the display and the instrument goes into the WAIT START status. At this point one should execute a further reset, which will cancel the set repetitions.

The number of repetitions is zeroed, returning into the 01/00 status.

NOTE: the reset does not work in the WAIT START condition (except for when the number of repetitions is cancelled).

13.3.5 SETTING THE NUMBER OF DOSAGE CYCLES

One can programme a series of automatic repetitions of the dosage cycles using a specific formula.

One should:

- 1) Press the **F8** key
- 2) Enter the number of repetitions to be executed (value which is between 0 and 999).
 - Formula Cycles = 0 → infinite repetitions with manual start through the START button.
 - Formula Cycles = 999 → infinite repetitions with automatic start.
 - Formula Cycles = n → executes n repetitions with automatic start .
- 3) Confirm the number of set cycles by pressing the ENTER key.

DESCRIPTION OF THE FUNCTION:

The display will show the number of executed cycle repetitions, which will increase at the end of each complete cycle, and the number of cycles to be executed:

CPWE/CPWETF



3590E



NOTE: In the approved versions just one cycle repetition is allowed, therefore it is possible to set a maximum number of cycles equal to 1.

(!) 000

13.3.6 QUICK CHANGE OF TARGET ACTIVITIES

Through this function one can quickly modify all targets of each activity of the selected formula

By pressing the **F3** key, one can access the menu to change quickly the activities target

Select the activity by using the arrow keys ▲ ▼ and press the **ENTER** key to change the activity target; press **C** key for clear.

Note: by setting a target equal to 0, the activity will not execute in the dosage (ONLY FOR LOAD AND TIMER ACTIVITIES).

Furthermore it is possible to combine up to 6 direct keys to the first 6 activities targets, through the functions from **317** to **322** (<< **F.KEYS** >> step, **TECH.MAN.REF.**), in this way by pressing the programmed key one can access directly to a specific target, for example **F1** key to quickly change the first target, and **F2** key to quickly change the second target.

13.4 TOLERANCE CHECK MODES

When the weigh is acquired, the instrument can follow two different ways, depending on the parameter set in the tolerance range enabling step << tSt.toL>>:

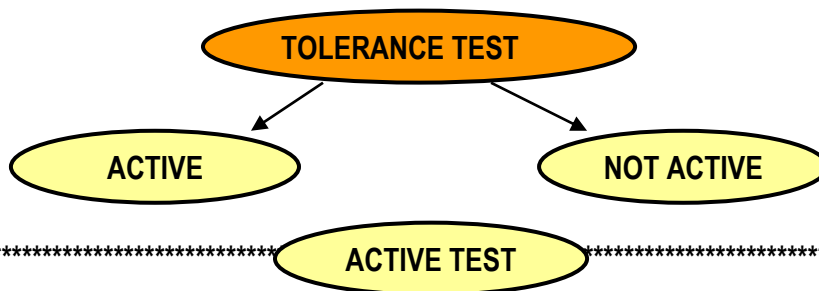

The instrument carries out the tolerance check, that is, it checks if the weight is within the tolerance interval set in the activity, then:

- IF THE WEIGHT IS WITHIN THE TOLERANCE INTERVAL, the instrument proceeds directly to the following activity

- IF THE WEIGHT IS NOT WITHIN THE TOLERANCE RANGE, the instrument waits for the eventual correction of the weight.

For details regarding the activity type see section 13.1.

The tolerance range may be set in 2 ways in the step << tSt.toL>>, as described in the next paragraphs.

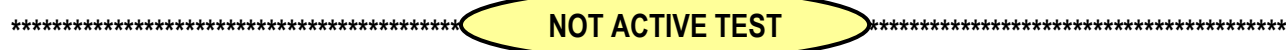

Once the dosage is ended, the instrument proceeds directly to the following activity.
For details depending on the activity type see section 13.1.

13.4.1 TOLERANCE EXPRESSED AS WEIGHT

While entering the activity, a tolerance can be entered expressed as a weight value, that defines a fixed tolerance range independently from the Target weight:

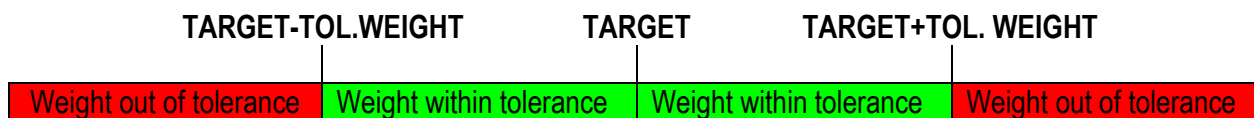

13.4.2 TOLERANCE EXPRESSED AS PERCENTAGE OF WEIGHT

While entering the activity, a tolerance value can be entered expressed as a weight percentile value based on the target weight entered in the formula; and therefore the tolerance weight can be calculated depending on the Target weight in order to increase the tolerance if the target is greater, and decrease it if the target is lower.

EXAMPLE

With Activity Tolerance Percentage Weight = 10%, one will have the following tolerance ranges:

- with target = 100 kg → Tolerance weight = +/- 10kg, therefore:

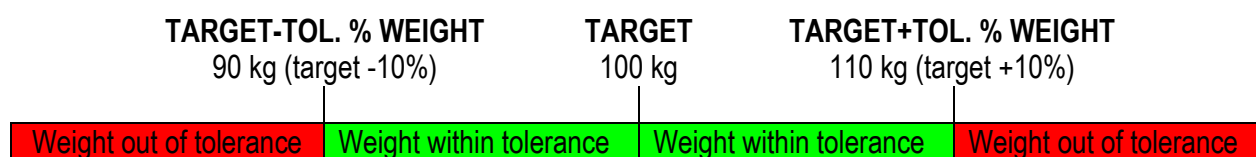

- with target = 200 kg → Tolerance weight = +/- 20kg, therefore:

**13.5 CORRECTION OF WEIGHT IN FLIGHT**

If the TOLERANCE TEST and the FLIGHT PERCENTILE CORRECTION has been enabled in the SETUP (TECH.MAN.REF), at the end of each dosage cycle within tolerance, the instrument calculates the difference between the programmed *flight weight* value and the one actually dosed in the following dosage cycle; the new *flight weight* to be taken into consideration will be the previous one plus or minus a fixed percentage of the measured difference, depending on the programmed value. This new calculated value will be the new reference for the following flight weight correction, and so on. The new value will substitute the one stored while entering the formula in the database, and it is possible to see it by printing the formula.

This functioning mode allows to obtain a progressive reduction of the correction value, and therefore a greater accuracy of the actual *flight weight*; this action can be buffered more or less by changing the programmed percentage value; by entering 100 there will be no buffering and the entire difference between the foreseen flight weight and the measured one will be summed with the actual flight weight in the following cycle.

A variable value from 1 to 100 represents the correction percentage which will be summed to the following cycle (for example, 50 causes the adding or the subtraction to the current flight weight of 50% of the previously calculated difference; in this way the correction will be buffered and less fast).

Higher the set value, and quicker will be the flight weight correction in the following dosage; vice versa, by putting low values it will gradually increase in the flight weight correction.

The use of the flight weight percentage correction is particularly useful in the dosage plants characterized by not always constant flight quantities. In the case of silos, for example, the quantity of material in the silo greatly influences the quantity of flight material to be taken into consideration.

13.6 MIN AND MAX LEVEL THRESHOLDS

By setting the minimum and maximum level thresholds, and by setting 2 outputs on the relative functions (signalising Min and Max levels), in the setup (TECH.MAN.REF), it is possible to enable these 2 outputs when the weight goes under the set minimum weight, or when it goes over the set maximum weight.

This can be useful as an alarm function for the operator, or as a signal for external devices that can manage the refilling of the silo for example.

The outputs are disabled immediately as soon as the weight pass again the level, therefore these can not be used to directly manage the refilling.

13.7 PRODUCTION PROGRAM

If this function is enabled, it allows to execute a production program cycle made up of up to 4 formulas that will be executed automatically in sequence one after the other.

ENABLING THE PRODUCTION PROGRAM

Through function 327 combinable with the desired key (<< F.KEYS >> step, TECH.MAN.REF.), one is asked to enable/disable the function. The same setting is possible also in the setup environment.

SETTING THE PRODUCTION PROGRAM

Through function **328** combinable with the desired key (<< **F.KEYS** >> step, **TECH.MAN.REF.**), one is asked first to input the number of formulas, from 1 to 4: press the enter key, input the number and confirm with enter.

After this, one is asked to select the formula position using the arrow keys \blacktriangle \blacktriangledown : press ENTER to confirm the formula to set, then select the formula using the arrow keys \blacktriangle \blacktriangledown and again ENTER to save.

Repeat the procedure for the set number of formulas and press C to exit the programming.

ENABLING PRODUCTION PROGRAM CYCLE

The cycle is automatically enabled as soon as it is programmed: the instrument enables the first programmed formula and wait its start.

It is possible to show the number of the formula in execution on the display, by selecting one of the foreseen visualizations (see section 4.2.4):

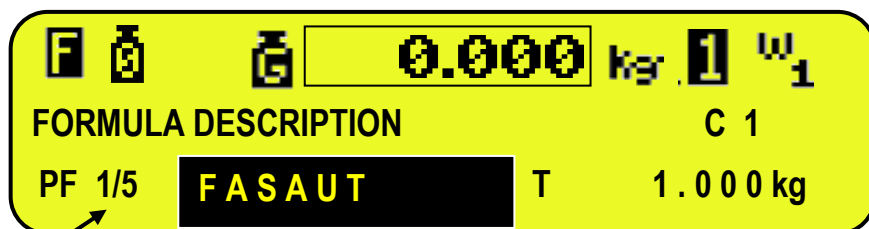

Number of formula in execution

PRINTING OF THE PRODUCTION PROGRAM REPORT

Through function **329**, combinable with the desired key (<< **F.KEYS** >> step, **TECH.MAN.REF.**), the report of the last executed production program is printed.

13.8 FUNCTIONING OF THE REMOTE COMPONENTS' DOSAGE

The function allows to control remotely an instrument (DGTQF,DGTPF,DGTPKF,DFWF series) so that it executes a single component dosage in the loading or unloading (see <<**btC.1-L**>> or <<**btC.1-u**>> step, see the relative technical manual), or multi components dosage (see <<**bAtCh**>> step, see the relative technical manual) in a 485 line through REMOTE DOSAGE and SYNCHRONIZATION activities (see the section 13.1.7 and 13.1.8).

NOTE:

if the multi component dosage is enabled, the function only works in the TOTAL WEIGHT mode (set in the **F.ModE** → **dosage** → **doS.PAr** → **EXE.For** step on the “**tot.WGt**”), otherwise when the input 1 is closed and the dosage starts, the display shows “REM. TARGET ERR.” message (see the section 4.2.5).

The user firstly should enter the formula to be dosed in the remote instrument, and can enter remote formula index in the remote dosage activity (see the section 11.1.1).

NOTE: if the target entered in the remote instrument and local indicator is different, it depends on the E-BATCH.

NOTE:

- To successfully set up the communication between the remote instruments and local indicator, one must set **Setup** → **Serial** → **Com pc** → **PC.Mode** step at “485” mode, otherwise when the input 1 is closed and the dosage starts, the display shows “PCMODE ERROR” message (see the section 4.2.5).
- The 485 address number of the local indicator must be different with remote instruments.
- The number of the remote instruments are up to 8 in a 485 line.

SEQUENTIAL / PARALLEL FUNCTION INTRODUCTION

For example 1:

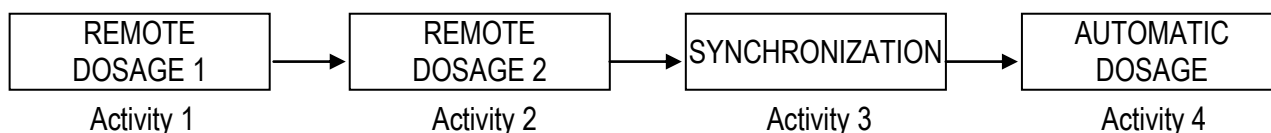

SCALE: 1	SCALE: 2	SCALE: 1
PARAMETER: PARALLEL	PARAMETER: PARALLEL	
REM.FORM INDEX: 0	REM.FORM INDEX: 1	

- The local indicator remotely enables the selected remote formula index (index 0 for remote dosage 1, index 1 for remote dosage 2) and transmit the set target to the remote instrument, while the remote instruments respectively clear the weight on the scale.
- The remote dosage 1 and 2 starts to execute dosage together.
NOTE: for any operation during the remote dosage, the relative instrument follows its own manual.
- Only when the remote dosage 1 is terminated, the automatic dosage starts.
If the SCALE is set at 255 in the "SYNCHRONIZATION" activity, when all the remote instruments dosage are terminated, the automatic dosage starts.

For example 2:

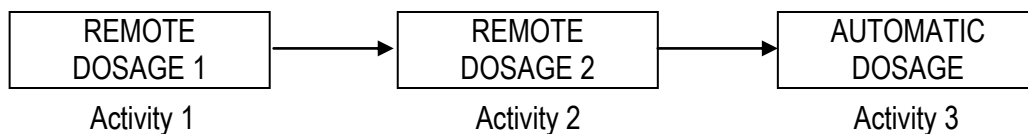

SCALE: 1	SCALE: 2
PARAMETER: SEQUENTIAL	PARAMETER: SEQUENTIAL
REM.FORM INDEX: 0	REM.FORM INDEX: 1

- The local indicator remotely enables the selected remote formula index (index 0 for remote dosage 1, index 1 for remote dosage 2) and transmit the set target to the remote instrument, while the remote instruments respectively clear weight on the scale.
- The remote dosage 1 starts to execute dosage.
NOTE: for any operation during the remote dosage, the relative instrument follows its own manual.
- Only when the remote dosage 1 is terminated, the remote dosage 2 starts to execute dosage.
- Only when the remote dosage 2 is terminated, the automatic dosage starts.

VIEWING THE PROGRESS BAR IN PERCENTAGE FOR THE REMOTE DOSAGE

Through function **331** combinable with the desired key (<< F.KEYS >> step, **TECH.MAN.REF.**), one is asked to know how many remote dosages have been done, and what is the status information for the remote instrument which happens during the dosage.

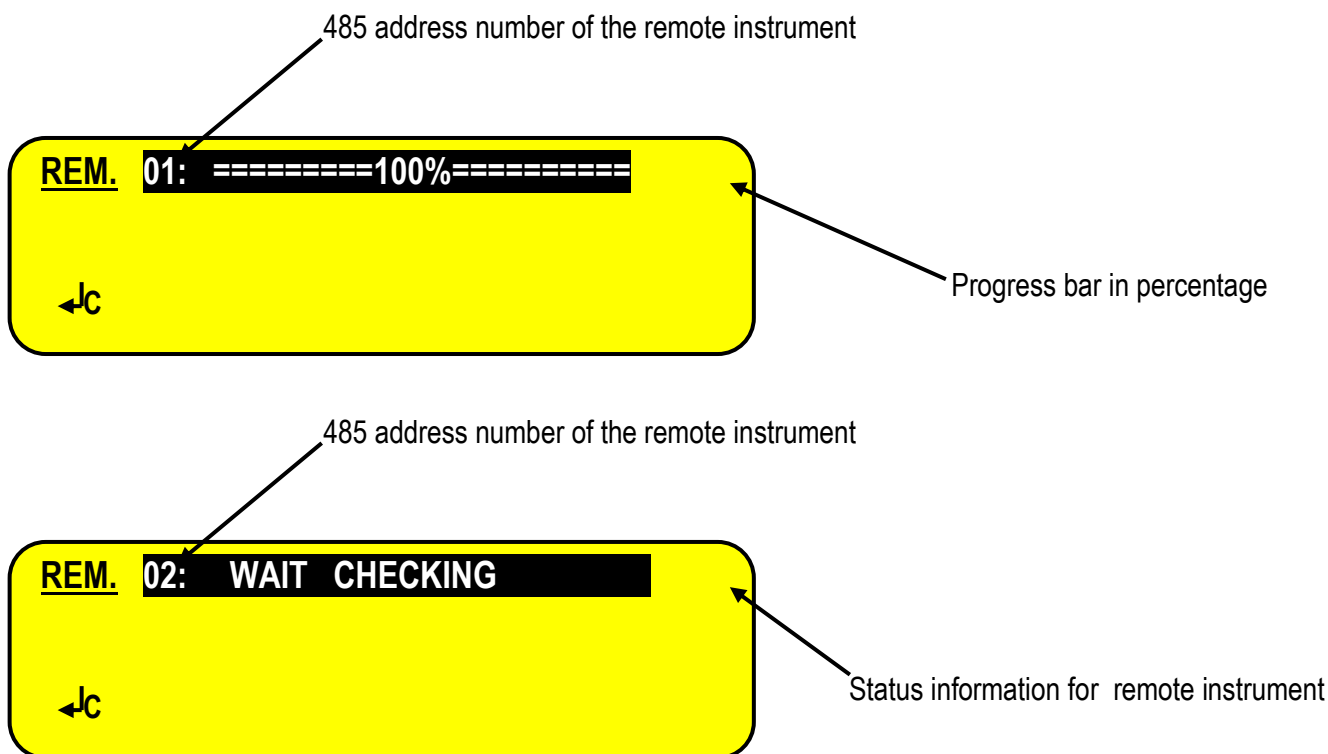

TESTING THE REMOTE COMMUNICATION

Through function **332** combinable with the desired key (<< F.KEYS >> step, **TECH.MAN.REF.**), one is asked to check if the communication is OK or not.

For example:

If the whole system is made of the 3 remote instruments and the 1 local indicator, and the 485 address of the local indicator is set at 04, the rest is set from 01 to 03, it is possible:

- 01: CONNECTED
- 02: CONNECTED
- 03: DISCONNECTED
- 04: LOCAL

13.9 EXAMPLE OF FORMULA AND DESCRIPTION OF EXECUTED CYCLE

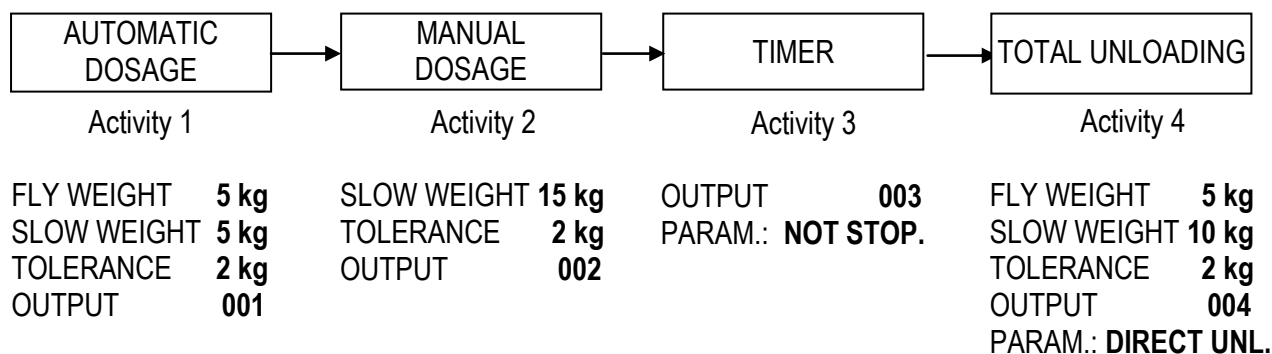

In the suggested example, the instrument will execute an automatic dosage as first activity, a manual dosage, a timer phase, and then, the total unloading of the silo. By pressing F1 to set the formula:

NUM. ACTIVITIES	04
PHS.001	Activity 1 AUTOMATIC DOSAGE
WEIGHT TO DOSE	50 kg
PHS.002	Activity 2 MANUAL DOSAGE
WEIGHT TO DOSE	80 kg
PHS.003	Activity 3 TIMER
WAIT TIME	20.0 s
PHS.004	Activity 4 UNLOAD
WEIGHT TO DOSE	130 kg
MIN TARE	2 kg
MAX TARE	6 kg

CONFIGURATION

In order to execute the formula one should:

- Select the formula.
- Once the relays OUT1 and OUT3 are enabled, put the initial tare on the plate, which must have a weight greater than 2 kg and less than 6 kg (the instrument displays "BEYOND MAX TARE" or "BELOW MIN TARE" to indicate respectively to increase and decrease the weight on the plate until it falls in this range). This weight includes also any possible semiautomatic or manual tare values.

The instrument:

- disables the ALARM output (default OUT3), and puts itself in a WAIT START status; the operator can give a start command (i.e. press the **F6** key or activate IN1), in order to start the dosage; the weight must be stable or, in any case, it must stabilize by the set time in the **<<WT.STAB>>** parameter (**TECH.MAN.REF.**); if this is not so, the error message "INSTABILITY ERR" is given and the OUT3 is enabled again, and the dosage will not begin. The operator can exit the error state through a start command.
- Resets the tare weight present (if no semiautomatic or manual tare value was entered previously), and enables the fast dosage output (OUT2) and OUT5 (which is the output linked to ACTIVITY 1), and starts to dose.
- Once the TARGET WEIGHT – FLIGHT WEIGHT – SLOW WEIGHT (50 – 5 – 5 kg) is reached, the instrument disables OUT2, the fast dosage is over, and the dosage starts at the minimum speed.

- f) Once the TARGET WEIGHT – FLIGHT WEIGHT (in other words $50 - 5 = 45$ kg) is reached, the instrument disables OUT 5 and the OUT2 and waits for the falling of the material in flight for the set time (**<<FLY.TIM>>**, **TECH.MAN.REF.**).
- g) Carries out the tolerance test, if enabled (**<<TST.TOL>>**, **TECH.MAN.REF.**), and then:
- will pass to the following phase if the weight is within tolerance, or
 - signals the weight out of tolerance error "TOL.ERR" and enables OUT3: the operator must manually adjust the dosed weight bringing it into tolerance (the display shows the "WEIGH OK" message) and gives a start command. In this way the instrument acquires the new dosed weight and will pass to the following phase. If the tolerance test is not enabled, after the **<<FLY.TIM>>** time, the instrument will pass to the following phase independently of the weight on the scale. If the dosed weight exceeds the set target, the OVER TARGET output (default OUT4) is enabled.
- h) Clears the weight, enables OUT2, OUT3 and OUT6 (which is the output linked to ACTIVITY 2) and the operator starts to manually dose the material on the scale.
- i) Keeps OUT2 enabled under the TARGET WEIGHT – SLOW WEIGHT ($80 - 15 = 65$ kg), and disables it when this threshold is reached. Keeps OUT3 enabled under the TARGET WEIGHT - TOLERANCE WEIGHT (in other words $80 - 2 = 78$ kg), and disables it if the weight exceeds this threshold.
- l) Keeps OUT6 enabled under the TARGET WEIGHT (80 kg), and disables it if the weight exceeds this threshold.
- m) Carries out the tolerance test, if enabled (**<<tSt.toL>>**, **TECH.MAN.REF.**), and then:
- shows the message "MAN OK" if the weight is within tolerance: with a start command the instrument will pass to the following phase; or
 - signals the weight out of tolerance error "MAN OFF" and enables relay OUT3: with a start command the instrument will pass to the following phase.
- If the tolerance test is not enabled, a start command with weight greater than the TARGET WEIGHT allows to pass to the following phase.
If the dosed weight exceeds the set target, the relay OUT4 is enabled.
- n) Disables OUT6, enables OUT7 (which is the output linked to ACTIVITY 3) and waits for 20 seconds.
- o) Disables OUT7, enables OUT2 and OUT8 (which is the output linked to ACTIVITY 4) and commands the complete unloading. When the weight is lower than the **<<End.unL>>** threshold, the instrument waits for **<<W.u.LoAd>>** seconds and disables OUT8.
- p) Once the complete unloading is executed, it continues:
- on step d) if the number of dosage cycles set in n.Cycle is not finished if the "tar.min" and "tar.max" parameters are set and the weight is under the "tar.min" or over "tar.max" at the dosage start, the "error" output is enabled and waits for the start command. Otherwise, the dosage starts automatically.
 - on step a) if the number of dosage cycles set in n.Cycle is finished, till the formula is not deselected.

NOTE: At any time it's possible to pause or reset the dosage by pressing the **F10** key or supplying an impulse through IN2.

14. PRINTOUTS

The instrument is fitted with various print functions, which may be used while weighing, and of 30 print formats, in other words, 30 different memory storages, each of which contain a programmable printout.

The printouts made by some of these functions depends on the print formats linked to it; see the following section for the linkages.

The format linking function allows to execute various printouts, by changing the linked format each time.

The available functions are:

SIMPLE PRINTOUT

- Programmable printout -

Through the **F5** key one prints the linked format:

With the APPROVED instrument:

- The printing works if there is a NET WEIGHT of at least 20 divisions.
- The printout is re-enabled depending on how the << rEAct >> parameter is configured

With the NON APPROVED instrument:

- The printing works if there is a NET WEIGHT greater than zero.
- The simple printout is always active (the programming of the << rEAct >> parameter is not taken into consideration).

DOSAGE REPORT

- Programmable printout -

Through the following print functions, it is possible to create a report of the dosage made by printing a heading, the weight of each weighed component and the dosage end, with all the data of the weighs and the accumulated total. See standard printout example in the section 14.5.

PRINTING OF THE HEADING (upon the first executed dosage):

- Programmable printout -

If a format is linked to the ("FIRST DOSAGE HEADING") function, first dosage, this will cause the printing of this format and then the format linked to the "START CYCLE" function.

Note: The heading format is printed only after the clearing of the production of the formula (see PRODUCTION printing function).

START CYCLE:

- Programmable printout -

By pressing the **F6** key, or through the INPUT 1, (START DOSAGE) the linked format is printed.

START DOSAGE ACTIVITIES:

- Programmable printouts -

At the start of each dosage activity the linked format is printed, depending on the type of activity.

END DOSAGE ACTIVITIES:

- Programmable printouts -

At the end of each dosage activity the linked format is printed, depending on the type of activity.

ACTIVITY DOSAGE OUT OF TOLERANCE:

- Programmable printout -

Each time the weight dosed is out of tolerance, the linked format is printed, depending on the type of activity.

END CYCLE/CYCLES:

- Programmable printout -

At the end of a formula:

- if only one cycle is configured, the format linked to the "END CYCLE" function is printed.
- if more than one cycle is configured, the format linked to the "END CYCLES" function is printed.

RESET CYCLE:

- Programmable printout -

By pressing two times the **F10** key (during the dosage), or through the INPUT 1, (PAUSE/RESET DOSAGE) the linked format is printed.

DOSAGE ERROR:

- Programmable printout -

The format linked to this function is printed when one of these errors will be shown on the display:

BEYOND MAX TARE
BELOW MIN. TARE
OUT OF ZERO
ERR. OUT OF ZERO
INSTABILITY ERR
ERR. OUT OF TIME
TOL. ERR
DOS+GROS > CAPAC

START PRODUCTION PROGRAM

- Programmable printout -

At the start of the first formula of each production program the linked format is printed.

END PRODUCTION PROGRAM

- Programmable printout -

At the end of each production program the linked format is printed.

GENERAL TOTAL

- Programmable printout -

By pressing the **F9** key the resetting of the GENERAL TOTAL and the printing of the linked format are made.

RESULT OF THE CALCULATOR

- Programmable printout -

Once enabled the operation with "CALCULATOR" function the linked format is printed. See section **15.3**.

PRINTING OF THE DATABASES

- Fixed printout -

By pressing the "**F5**" key inside the databases it is possible to print a report of the ACTIVITIES DATABASE, FORMULAS DATABASE (see sections 11.1.4, 11.2.4).

The printing made with the **F5** key must be recalled within each single database.

REPORT OF ALL THE ACTIVITIES

- Fixed printout -

Through function **304**, combinable with the desired key (<< **F.KEYS** >> step, **TECH.MAN.REF.**), a report of the activities in the database is printed.

CONSUMPTIONS OF ALL THE ACTIVITIES

- Fixed printout -

Through function **305**, combinable with the desired key (<< **F.KEYS** >> step, **TECH.MAN.REF.**), the resetting and the printing of the consumptions of all activities in the database are made.

REPORT OF A SPECIFIC FORMULA

- Fixed printout -

Through function **307**, combinable with the desired key (<< **F.KEYS** >> step, **TECH.MAN.REF.**), a report of a specific formula in the database can be printed: with the arrow keys ▲ ▼ scroll the formula database until you find the desired one and use the ENTER key to select the formula and print the report.

REPORT OF ALL THE FORMULAS

- Fixed printout -

Through function **308**, combinable with the desired key (<< **F.KEYS** >> step, **TECH.MAN.REF.**), a report of all the formulas in the database is printed.

PRODUCTION OF A SPECIFIC FORMULA

- Fixed printout -

Through function **309**, combinable with the desired key (<< **F.KEYS** >> step, **TECH.MAN.REF.**), the resetting and the printing of the production of a specific formula in the database can be made: with the arrow keys ▲ ▼ scroll the formula database until you find the desired one and use the ENTER key to select the formula and print its consumptions.

PRODUCTION OF ALL THE FORMULAS

- Fixed printout -

Through function **310**, combinable with the desired key (<< **F.KEYS** >> step, **TECH.MAN.REF.**), the resetting and the printing of all the production formulas in the database are made.

REPORT OF THE SELECTED FORMULA

- Fixed printout -

Through function **325**, combinable with the desired key (<< **F.KEYS** >> step, **TECH.MAN.REF.**), a report of the selected formula in the database is printed.

PRODUCTION OF THE SELECTED FORMULA

- Fixed printout -

Through function **326**, combinable with the desired key (<< **F.KEYS** >> step, **TECH.MAN.REF.**), the resetting and the printing of the selected production formula in the database are made.

PRODUCTION PROGRAM

- Fixed printout -

Through function **329**, combinable with the desired key (<< **F.KEYS** >> step, **TECH.MAN.REF.**), the report of the last executed production program (see section 13.7) is printed.

14.1 LINKING OF THE FORMATS TO THE PRINT FUNCTIONS

Through function **200**, combinable with the desired key (<< **F.KEYS** >> step, **TECH.MAN.REF.**), one accesses the linking of the print formats (configurable in the **SEtuP** >> **SEriAL** >> **Prn.FMt** step **TECH.MAN.REF.**) to the 30 programmable print functions:

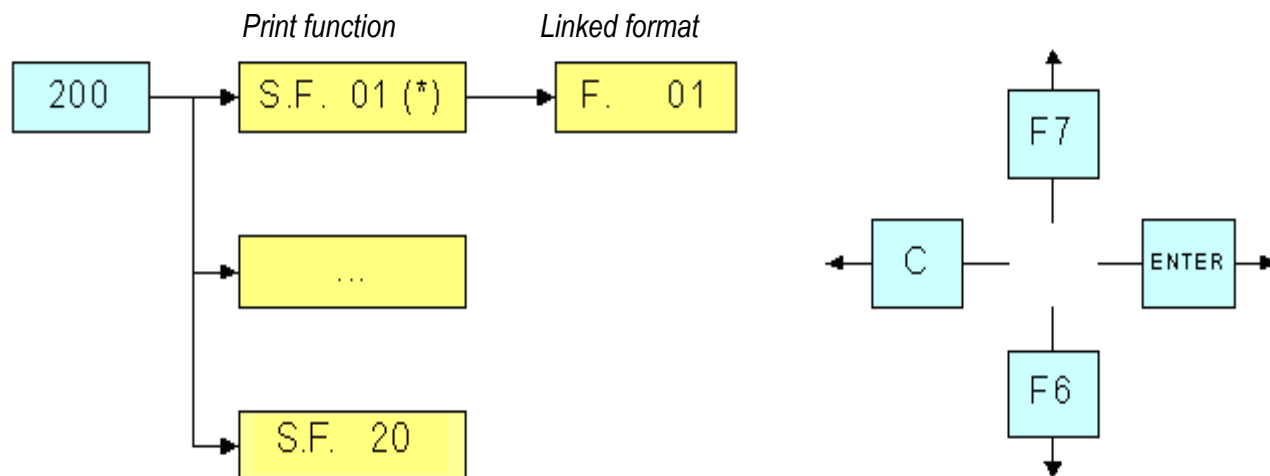

Print function		Key	Linked step	
SIMPLE PRINTOUT		F5	S.F. 01	
DOSAGE REPORT	HEADING OF THE FIRST DOSAGE	Automatic entry	S.F. 02	
	START CYCLE	F6	S.F. 03	
	START AUTOMATIC DOSAGE	Automatic entry	S.F. 04	
	END AUTOMATIC DOSAGE	Automatic entry	S.F. 05	
	OUT OF TOLERANCE AUTOMATIC DOSAGE	Automatic entry	S.F. 06	
	START MANUAL DOSAGE	Automatic entry	S.F. 07	
	END MANUAL DOSAGE	Automatic entry	S.F. 08	
	OUT OF TOLERANCE MANUAL DOSAGE	Automatic entry	S.F. 09	
	START TOTAL UNLOAD	Automatic entry	S.F. 10	
	END TOTAL UNLOAD	Automatic entry	S.F. 11	
	OUT OF TOLERANCE TOTAL UNLOAD	Automatic entry	S.F. 12	
	START PARTIAL UNLOAD	Automatic entry	S.F. 13	
	END PARTIAL UNLOAD	Automatic entry	S.F. 14	
	OUT OF TOLERANCE PARTIAL UNLOAD	Automatic entry	S.F. 15	
	START MANUAL WEIGHT DOSAGE	Automatic entry	S.F. 16	
	END MANUAL WEIGHT DOSAGE	Automatic entry	S.F. 17	
	OUT OF TOLERANCE MANUAL WEIGHT DOSAGE	Automatic entry	S.F. 18	
	END PAUSE ACTIVITY	Automatic entry	S.F. 19	
	END TIMER ACTIVITY	Automatic entry	S.F. 20	
	END CYCLE	Automatic entry	S.F. 21	
	RESET CYCLE	F10	S.F. 22	
	DOSAGE ERROR	Automatic entry	S.F. 23	
	START TIMER ACTIVITY	Automatic entry	S.F. 25	
	START PAUSE ACTIVITY	Automatic entry	S.F. 26	
	END CYCLES	Automatic entry	S.F. 27	
	START PRODUCTION PROGRAM	Automatic entry	S.F. 28	
	END PRODUCTION PROGRAM	Automatic entry	S.F. 29	
	GENERAL TOTAL		F9	S.F. 24
	CALCULATOR (see section 15.2)		Automatic entry	S.F. 30

The instrument is fitted with 30 print formats, in other words, 30 different storages, each of which contain a programmable printout.

The formats are programmable in the **SEtuP >> SEriAL >> Prn.FMt** step in the SET-UP environment (**TECH.MAN.REF.**).

It's possible to quickly link to each print function listed in the table to a stored format; this function allows also to execute various printouts with the same print function, changing the linked format from time to time.

TO LINK THE FORMAT:

- Recall function **200**, combinable with the desired key (<< **F.KEYS** >> step, **TECH.MAN.REF.**).

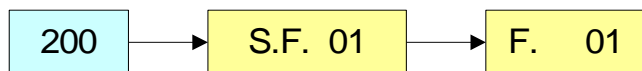

- The LCD display shows:

XX in which:

XX indicates the number of the function (from 01 onwards) to which the print format is linked.

- Select the print function (for example S.F. 01) through the arrow keys ▲ ▼ and press the **ENTER** key
- Once entered, the display shows:

XX in which:

XX indicates the number of the format to be linked to the function.

- Type the format number and press **ENTER**.

NOTE: In order to not link any format to a vector one should enter the number 00.

14.1.1 QUICK LINKING OF A SPECIFIC PRINT FUNCTION

By linking the number of a specific print function to the function **200** (preamble function in the << **F.KEYS** >> step, **TECH.MAN.REF.**), it is possible to access directly to the modification of it with a direct key, for example F1 key to quickly link the S.F. 1, and F2 key to quickly link the S.F. 2.

TO QUICK LINK THE FORMAT:

- Recall the desired print function, by pressing the linked key (<< **F.KEYS** >> step, **TECH.MAN.REF.**).

- The LCD display shows:

XX in which:

XX indicates the number of the format to be linked.

- Type the format number and press **ENTER**.

NOTE: In order to not link any format to a print function one should enter the number 00.

14.2 TICKET PROGRESSIVE SETTING**14.2.1 PROGRESSIVE DIGITS**

Through function **400**, combinable with the desired key (<< **F.KEYS** >> step, **TECH.MAN.REF.**), it's possible to set the number of digits with which the TICKET PROGRESSIVE is printed.

It's also possible to quickly set the number of progressive digits by entering the corresponding value through the numeric keys and then pressing the key combined with the function 400.

The number of settable digits varies from 4 to 16, organised in this way:

- if the actual digits of the total are less than the number of digits set in this step, the difference is filled with some spaces.
- if the actual digits are greater than the number of digits set in this step, only the ones actually entered are taken into consideration (counting from right to left).

The alignment of the total fields is on the left.

NOTE: The number of settable digits DOES NOT INCLUDE the comma.

14.2.2 TICKET PROGRESSIVE

Through function **401**, combinable with the desired key (<< **F.KEYS** >> step, **TECH.MAN.REF.**), it's possible to modify or clear the TICKET PROGRESSIVE.

It's also possible to quickly modify the ticket progressive by entering the corresponding value through the numeric keys and then pressing the key combined with the function 401.

The TICKET PROGRESSIVE is a progressive number which increments of one at every general total clearing.

14.3 REPETITION OF THE LAST EXECUTED PRINTOUT

By pressing in sequence the **2ndF** and **F5** keys the last executed printout is repeated; the printout can be repeated many times, until a new printout is executed.

14.4 DEFAULT PRINTING FORMATS

The **SEtuP >> SEriAL >> dEF.Prn** parameter of the set-up environment (**TECH.MAN.REF.**) allows to enable the default printouts for the TPR printer.

NOTE: By enabling these printouts all the formatted print formats will be CANCELLED and will be SUBSTITUTED by the standard formats, which automatically will be linked to the available print functions.

14.5 STANDARD PRINTOUT EXAMPLES

DOSAGE REPORT

JIM SMITH COMPANY
 17, MAIN STREET
 NEW YORK, NY U.S.A

 TEST
 TARGET 110kg
 CYCLE REPORT 01
 9/11/09 - 15:22

01 AUTOM. DOSAGE
 GRAVEL
 SCALE NUMBER 1
 DOSE 50kg
 DOSED WEIGHT 50kg

02 MANUAL DOSAGE
 SAND
 SCALE NUMBER 1
 DOSE 50kg
 DOSED WEIGHT 50kg

03 MANUAL WEIGHT
 KAOLIN
 SCALE NUMBER 1
 DOSE 10kg
 DOSED 10kg

06 UNLOAD
 DISCHARGE
 UNLOADED 110kg

CYCLE REPORT
 9/11/09 - 15:30
 TARGET 110kg
 DOSED 110kg
 OUT OF TOL. 0kg

PRINT CONSUMPTIONS DOSAGE ACTIVITIES

 CONSUMP. REPORT
 CONSUMED TILL: 08/04/08

CONSUMED FROM: 07/04/08
 GRAVEL
 197kg

CONSUMED FROM: 07/04/08
 SAND
 101kg

CONSUMED FROM: 07/04/08
 KAOLIN
 30kg

GENERAL TOTAL

GENERAL TOTAL
 25/02/08
 CYCLES TOTAL 1
 CYCLES OK 1
 CYCLES OFF 0
 ERROR 0kg
 DOSED TOTAL 215kg
 IN TOLERANCE 215kg
 OUT OF TOL. 0kg

REPORT OF ALL THE DOSAGE ACTIVITIES

 ACTIVITY REPORT
 08/04/08 11:11

GRAVEL
 AUTOM. DOSAGE OUTPUT 01
 TOLERANCE 4kg
 FLIGHT 5kg
 SLOW 6kg
 SCALE 1

SAND
 MANUAL DOSAGE OUTPUT 02
 TOLERANCE 5kg
 SLOW 6kg
 SCALE 1

WAITING
 TIMER OUTPUT 03
 SCALE 1

FORMULA REPORT

25/02/08

FORMULA REPORT

TEST

MIN. TARE 0kg
MAX. TARE 0kg
-----1 GRAVEL
AUTOM. DOSAGE
TARGET 200kg
TOLERANCE 3kg
FLIGHT 4kg
SLOW 5kg
SCALE 1
-----2 SAND
MANUAL DOSAGE
TARGET 101kg
TOLERANCE 5kg
SLOW 6kg
SCALE 1
-----3 KAOLIN
MANUAL WEIGHT
TARGET 30kg
TOLERANCE 0kg
SLOW 0kg
SCALE 1
-----4 TIMER 3.000sec
TIMER
SCALE 1
-----5 DISCHARGE
COMPLETE
SCALE 1
-----TOTAL 331kg

PRODUCTION OF A FORMULA

PRODUCTION REPORT
PRODUCTION TILL:08/04/08PRODUCED FROM: 07/04/08
TEST
DOSED TOTAL 993kg
OUT OF TOL. 205kg
IN TOLERANCE 788kg
CYCLES TOTAL 1
CYCLES OK 1
CYCLES OFF 0

PRINT KEY

JIM SMITH COMPANY
17, MAIN STREET
NEW YORK, NY U.S.A
SCALE NUMBER 1
GROSS = 1.050kg
TARE = 0.050kg
NET = 1.000kg
9/11/09 - 15:22

REMOTE DOSAGE

REG
TARGET 6.0kgCYCLE REPORT 01
18/11/10 - 22:54:49
-----01 REMOTE COMPONENTS
REMOTE
ADDRESS NUMBER 1
DOSE 3.0kg
ADDRESS NUMBER 1
DOSED WEIGHT 3.0kg02 REMOTE COMPONENTS
REMOTE2
ADDRESS NUMBER 2
DOSE 3.0kg
ADDRESS NUMBER 2
DOSED WEIGHT 3.0kg
-----CYCLE REPORT
18/11/10 - 22:55:27
TARGET 6.0kg
DOSED 6.0kg
OUT OF TOL. 0.0kg

15. OTHER FUNCTIONS

15.1 DIAGNOSTIC PERIPHERALS

Through function 118 combinable with the desired key (<< F.KEYS >> step, TECH.MAN.REF.), one enables the diagnostic peripherals function.

The display shows:

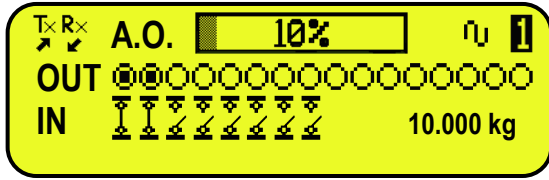

STATUS	DESCRIPTION
ANALOGUE OUTPUT(A.O)	Analogue output value expresses as a percentage.
OUTPUTS (OUT)	Status of the output, non active (○) or active (◐).
INPUTS (IN)	Status of the input, non active (⏏) or active (⏏).
SERIAL COMMUNICATION (Tx Rx)	The serial communication is active with the external device.
WEIGHT	Status of the weight: - unloaded scale; - unstable weight;
SCALE	Number of the active scale (example 1 , see section 5 SCALE SELECTION) and the relative weight loaded.

15.2 COM DATA DIAGNOSTIC

Through function 119 combinable with the desired key (<< F.KEYS >> step, TECH.MAN.REF.), one enables the Com data diagnostic function. The display shows:

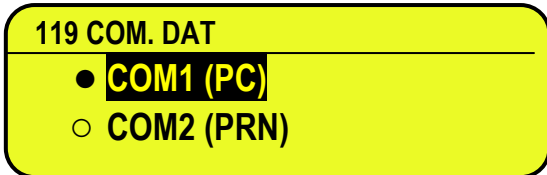

In the first screen one selects the port on which the diagnostic control should be executed. While in the second screen, one selects the code that one wants to use for viewing the data in transit.

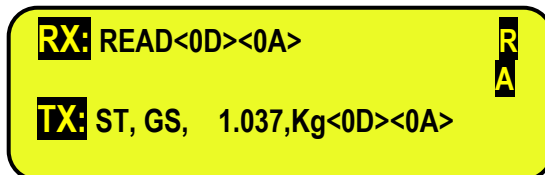

When the data on the RX and TX reception and transmission lines are correctly displayed, then the functioning of the relative serial line is considered to be correct.

NOTE: By pressing the .HELP key, it's possible to see the keys list used in the menu.

15.3 CALCULATOR

Through function **114** combinable with the desired key (<< **F.KEYS** >> step, **TECH.MAN.REF.**), one enables the calculator function.

- **ADDITION**
- **MULTIPLICATION**
- **SUBTRACTION**

Procedure:

- Enter the first value using the numerical keyboard.
- Press **F1** to add, **F2** to multiply, **F3** to subtract the value.

TERMINATE THE OPERATION:

- **TYPE** the second value and **PRESS ENTER**: the result will be shown for a few seconds on the display.
- **TYPE** the second value and **PRESS TARE**: the result will be shown for a few seconds on the display and will be added (if an addition and multiplication) or subtracted (if a subtraction) to the current tare value.
- **PRESS 2nd F**: the NET weight on the scale will be used as a second value and the result will be shown for a few seconds on the display.

To disable the calculator function, press the C key.

15.3.1 HELP FUNCTION

By pressing at length the **. /HELP** key it is possible to see the list of the keys used in the calculator function.

The list is automatically scrolled. If one wants to scroll the list of the keys in manual mode, it is possible to use the arrow keys (F6 ▼ and F7 ▲).

15.4 DISPLAY OF NET WEIGHT WITH SENSITIVITY X 10 (for testing use during calibration)

By pressing at length the **F2** key one will view the net weight with sensitivity times 10 (press again at length the **F2** key to return to the normal visualisation).

NOTES:

- With approved indicator, the visualisation lasts about 5 seconds, after which it's disabled.
- The printout can only be done when the indicator has the standard sensitivity.

LIMITATION OF THE FUNCTION

For specific requirements, it is possible to limit the function **with approved instrument**.

By setting "YES" in the **SEtuP >> d.SALE** step and "no" in the **SEtuP >> d.SALE >> REM.DSP** step, the function will be disabled.

15.5 SETTING DATE / TIME

By pressing at length the **F3** key it's possible to quickly access the setting from the date / time of the instrument:

DAY ⇒ **ENTER** ⇒ MONTH ⇒ **ENTER** ⇒ YEAR ⇒ **ENTER** ⇒ HOUR ⇒ **ENTER** ⇒ MINUTES ⇒ **ENTER**.

15.6 CUSTOM DISPLAY

Through function **120** combinable with the desired key (<< **F.KEYS** >> step, **TECH.MAN.REF.**), one enables the custom display function. The display shows:

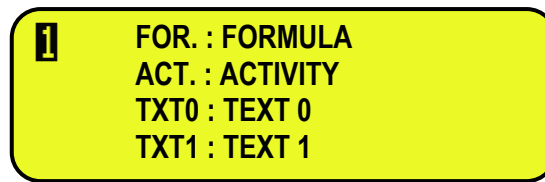

In which:

- "FOR." indicates formula description.
- "ACT." indicates activity description in the formula.
- "TXT0" indicates the contents of the input text 0.
- "TXT1" indicates the contents of the input text 1.

Each row contains up to 22 characters.

By pressing **Fn + F9** it's possible to directly enable the function; by pressing **2ndF + F9** it's possible to change the visualizations on the LCD display to disable the function.

NOTE: The function is only for the 3590E indicator.

DECLARATION OF CONFORMITY

This device conforms to the essential standards and norms relative to the applicable European regulations. The Declaration of conformity is available in the web site www.diniargeo.com.

WARRANTY

The TWO-YEAR warranty period begins on the day the instrument is delivered. It includes spare parts and labour for repairs at no charge if the INSTRUMENTS ARE RETURNED prepaid to the DEALER'S PLACE OF BUSINESS. Warranty covers all defects NOT attributable to the Customer (such as improper use) and NOT caused during transport.

If on site service is requested (or necessary), for any reason, where the instrument is used, the Customer will pay for all of the service technician's costs: travel time and expenses plus room and board (if any).

The customer pays for shipping costs (both ways), if the instrument is shipped to the DEALER or manufacturer for repair.

The WARRANTY is VOIDED if faults occur due to work done by unauthorized personnel or due to connections to equipment installed by others or incorrect connection to the power supply.

This warranty DOES NOT provide for any compensation for losses or damages, direct or indirect, incurred by the Customer due to complete or partial failure of instruments or systems sold, even during the warranty period.

AUTHORISED SERVICE CENTRE STAMP

